



NEP-ZL106636

INSTALLATION OPERATION & MAINTENANCE

NEPTUNE SERIES JG Gear Drive SERIES JD Direct Drive Clamp Mount Mixer

PLUS:

JGR and JDR Angle
Riser Mount

JGF and JDF
Flange Mount

PSG
22069 Van Buren Street
Grand Terrace, CA 92313 USA
P: +1 (215) 699-8700 F: +1 (215) 699-0370
neptune1.com

Copyright 2018 PSG®, a Dover Company

NEP-ZL106636
03.2018_REV 2



WARNING

LOCKOUTS ARE REQUIRED BEFORE
SERVICING THIS EQUIPMENT.

SAFETY INSTRUCTIONS:

Shut off/Lockout Mixer Power before Servicing.

DO NOT OPERATE MIXER UNLESS PROPERLY INSTALLED, AVOID
ROTATING SHAFT AND BLADES, TURN OFF POWER AND
LOCKOUT EQUIPMENT BEFORE ADJUSTING OR SERVICING, ETC.

TABLE OF CONTENTS

| | PAGE |
|--|------|
| WARRANTY | 1 |
| PARTS ORDERING INSTRUCTIONS | 2 |
| MIXER POSITIONING | 3 |
| INTRODUCTION | 4 |
| SHAFT INSTALLATION INSTRUCTIONS | 5 |
| SHAFT AND PROPELLER PARTS LIST | 6 |
| PARTS LIST For Series JG Clamp Mount Model Mixers | 7 |
| Mixer Model JG Drawing No. S00070 | 8 |
| PARTS LIST For Series JD Clamp Mount Model Mixers | 9 |
| Mixer Model JD Drawing No. S00072 | 10 |
| PARTS LIST For Series JGR and JDR Angle Riser Mount Model Mixers | 11 |
| Angle Riser Mount Drawing No. S00051 | 12 |
| PARTS LIST For Series JGF and JDF Stuffing-Box Model Mixers | 13 |
| Flange Mounting Unit Drawing No. S00073 | 14 |
| MSDS Sheets | 15 |

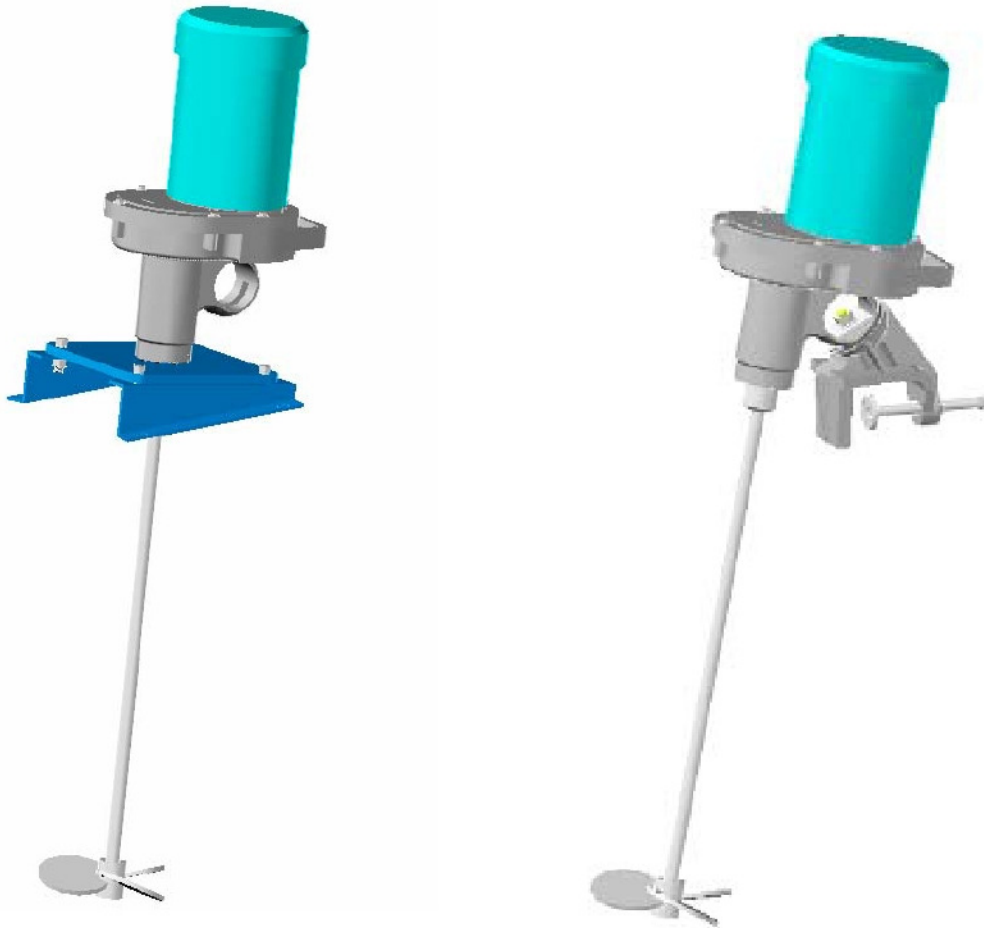

LIMITED WARRANTY

All Neptune Mixers are tested at the factory prior to shipment. Each part used in their construction has been carefully checked for workmanship.

If the Mixer is installed properly, Neptune Chemical Pump Company warrants to the purchaser of this product for a period of one year from the date of shipment, whichever occurs first, this product shall be free of defects in material and/or workmanship, as follows:

1. Neptune Chemical Pump Company will replace, at no charge, any part that fails due to a defect in material and/or workmanship during the warranty period, FOB our factory, North Wales, Pennsylvania. To obtain warranty service, you must get an RMA number to return the defective parts to the factory for examination, freight pre-paid.
2. This warranty period does not cover any product or product part, which has been subject to accident, misuse, abuse or negligence. Neptune Chemical Pump Company shall only be liable under this warranty if the product is used in the manner intended by the manufacturer as specified in the written instructions furnished with this product.

Any express warranty not provided in this warranty document, and any remedy for breach of contract that, but for this provision, might arise by implication or operation of law, is hereby excluded and disclaimed. Under no circumstances shall Neptune Chemical Pump Company be liable to purchaser or any other person for any charge for labor, repairs, or parts, performed or furnished by others, nor for any incidental consequential damages, whether arising out of breach of warranty, express or implied, a breach of contract or otherwise. Except to the extent prohibited by applicable law, any implied warranty of merchantability and fitness for a particular purpose are expressly limited in duration to the duration of this limited warranty.

Some states do not allow the exclusion or limitation of incidental or consequential damages, or allow limitations on how long any implied warranty lasts, so the above limitations may not apply to you. This warranty gives you specific legal rights, and you may have other rights, which may vary from state to state.

IMPORTANT

SHOULD IT BE NECESSARY TO SEND THE PUMP TO THE FACTORY FOR REPAIR OR MAINTENANCE REBUILDING; DRAIN ALL OIL AND CHEMICAL FROM PUMP BEFORE SHIPPING. FAILURE TO DO SO CAN CAUSE EXTENSIVE DAMAGE TO THE MOTOR.

¹SEE IMPORTANT NOTICE - RETURN GOODS AUTHORIZATION

IMPORTANT NOTICE RETURN GOODS AUTHORIZATION

- (1) All equipment returned to Neptune Chemical Pump Company requires proper Returned Goods Authorization Number (RGA) and tags.
- (2) All equipment returned to the factory for repair or service must first be thoroughly flushed and have all chemical contact areas neutralized.
- (3) All equipment which has been in contact with chemicals must be accompanied by a copy of the Chemical Product Material Safety Data Sheet (MSDS).
- (4) Failure to comply with the above instructions will result in equipment being returned to sender, freight collect, without service.

PARTS ORDERING INSTRUCTIONS

The complete model number and serial number of the pump must be furnished to insure prompt and accurate parts service. These numbers are found on the name plate (sample below) located on the side of the mixer. Refer to Pages 6, 7, 9, 11 and 13 for complete parts lists.



Send all orders or inquiries for parts to:

Parts Department
Neptune Chemical Pump Company
295 DeKalb Pike
North Wales, PA 19454
Tel.: 215-699-8700
1 -888-3NEPTUNE (888-363-7886)
FAX: 215-699-0370
Web: www.neptune1.com
Email: pump@neptune1.com

NOTE: PLEASE SUPPLY BOTH MODEL AND SERIAL NUMBERS.

MIXER POSITIONING

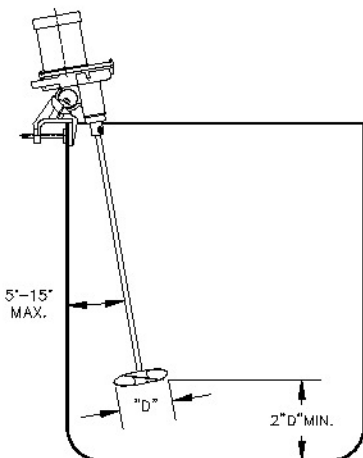
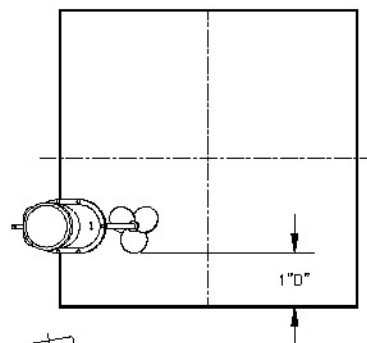
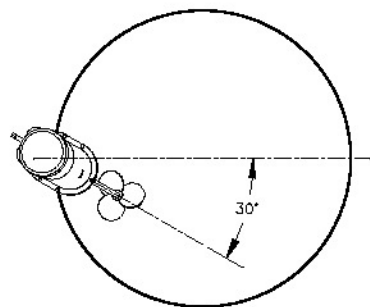

VERTICAL
CYLINDRICAL

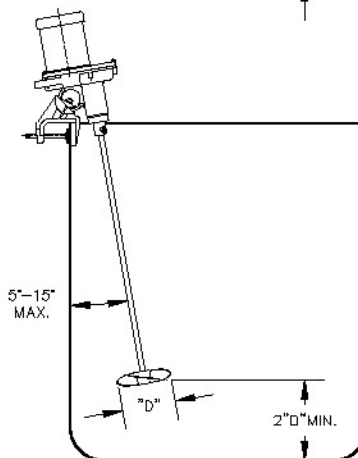

CUBICAL
(L=W)

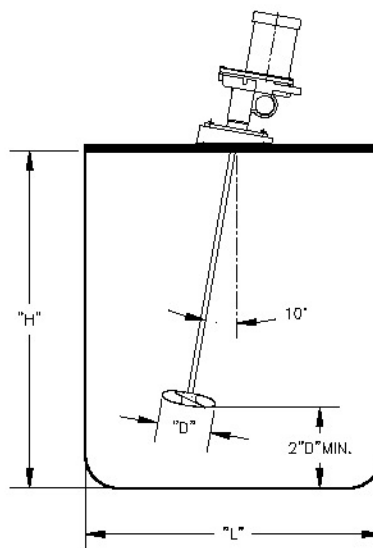
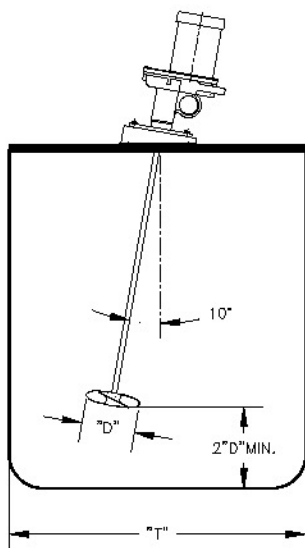
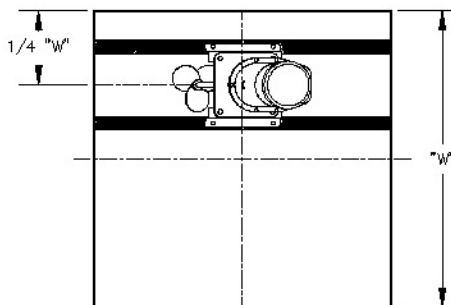
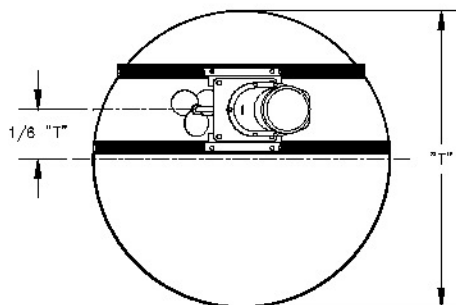

"T" = TANK DIAMETER
"D" = IMPELLER DIAMETER

INTRODUCTION

The Neptune Mixer is a carefully designed piece of precision equipment which will give you years of satisfactory service under normal operating conditions.

A. INSPECTION

All Neptune Mixers are shipped in a specially designed carton to insure against damage in shipment. Each shaft is shipped in an individual box. Upon receipt, examine the mixer for damage; report any damage to Neptune and the delivering carrier at once.

B. LUBRICATION/MAINTENANCE

The outboard ball bearing [30] and upper ball bearing [27] are sealed and pre-greased for bearing life. The gear box is lubricated at the factory. Neptune recommends changing grease annually. To change grease or to change the motor: Remove motor midplate (fig. 21) by taking out the six bolts & washers (fig. 14/15). Remove motor and midplate (they will be attached) from gearbox. Remove four motor bolts (fig. 12/13) underneath midplate. Clean gear box and gears with solvent. Coat gears with about 4.8 oz of the following grease.

Mixers use Bel-Ray® 72560 Grease. Order P/N 104750

C. MOUNTING THE MIXER

Remove the mixer from the carton and attach clamp. Rotate the clamp to an initial position such that the motor will be upright when the unit is clamped to the tank. Place the clamp on the desired location on the tank, being certain that both the horizontal and vertical surfaces of the clamp are in contact with the top and side of the tank. Rotate the nut clockwise to tighten; counter clockwise to loosen.

D. MOUNTING MIXER SHAFT

Neptune supplies standard square pitch propellers which may be put on the mixer shaft either face up or face down. Place the propellers on the end of the shaft WITHOUT THE NOTCHES. If two propellers are used, they should be spaced at least two propeller diameters apart. Be certain to securely tighten the propeller set screws. Place the end of shaft with the notches into the shaft collar until it bottoms. Screw in the setscrews [32]. Rotate the shaft to line up the shaft notches with setscrews [32] and tighten the setscrews. (See Shaft Installation Diagram on pg. 5.)

E. ELECTRICAL CONNECTIONS

Your Neptune mixer is designed to rotate clockwise when looking down from the top of the motor. This is so indicated by arrows cast on the motor midplate.

Follow the wiring directions as indicated on the motor to obtain proper rotation. Jog motor to check propeller rotation.

F. MIXER POSITIONING

To utilize energy supplied by the mixer, a top to bottom turnover of the liquid should be created. The mixer shaft should be angled 5° to 15° off vertical wall of tank pointed 20° to 30° right of the center line. Refer to diagrams on page 3.

Moving the shaft to the left of the position described will increase swirl of vortex. This helps to submerge light powders and to aerate the mix but decreases mixing efficiency. Adjust vortexing by changing shaft position and angle (Stay within maximum limits).

G. MIXER OPERATION

Neptune mixers are designed for continuous operation under normal conditions. It is not a good practice to operate continuously when extreme vortexing occurs. Mixer Propellers must be submerged in the Liquid during mixing operation or damage could occur.

After mixer has been turned on and the mixing pattern developed, adjust mixer position if necessary.
DO NOT ADJUST WHILE RUNNING

After ten days of operation, check the Motor Midplate screws, and shaft collar Hex Nut for tightness. At the end of a mixing period, it is a good practice to turn off the mixer before the tank is drained. Turn mixer off when liquid level is one propeller diameter above lower propeller.

MIXERS MANUFACTURED BEFORE DECEMBER 2010

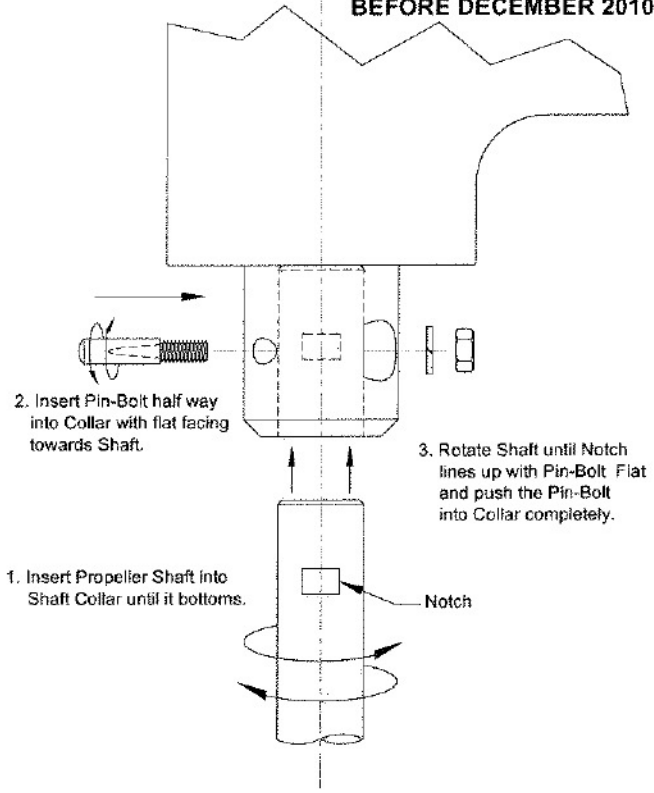

MIXERS MANUFACTURED AFTER DECEMBER 2010

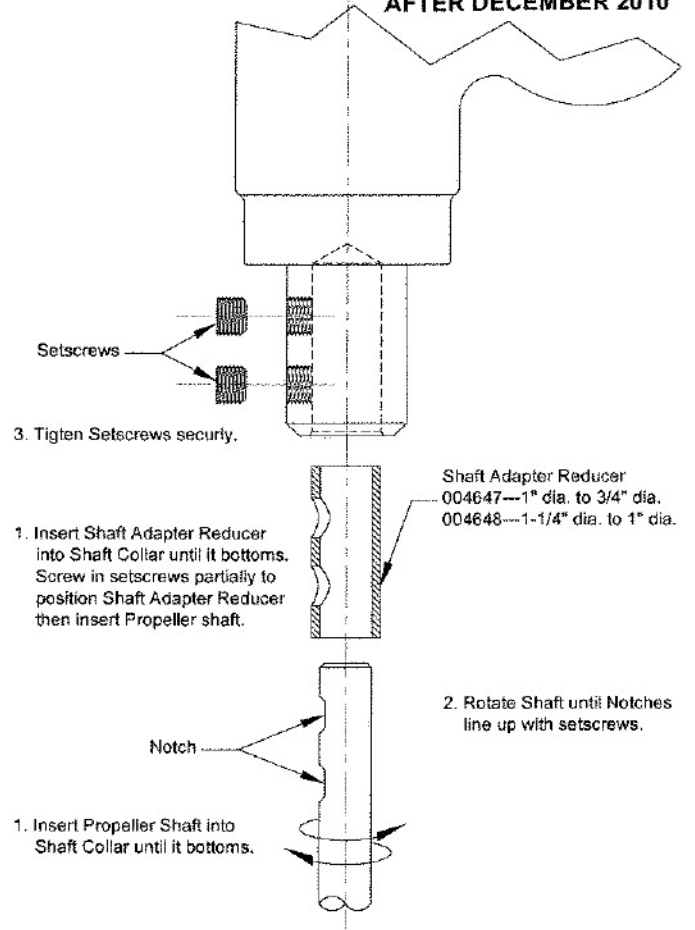

MIXERS MANUFACTURED AFTER SEPTEMBER 2012

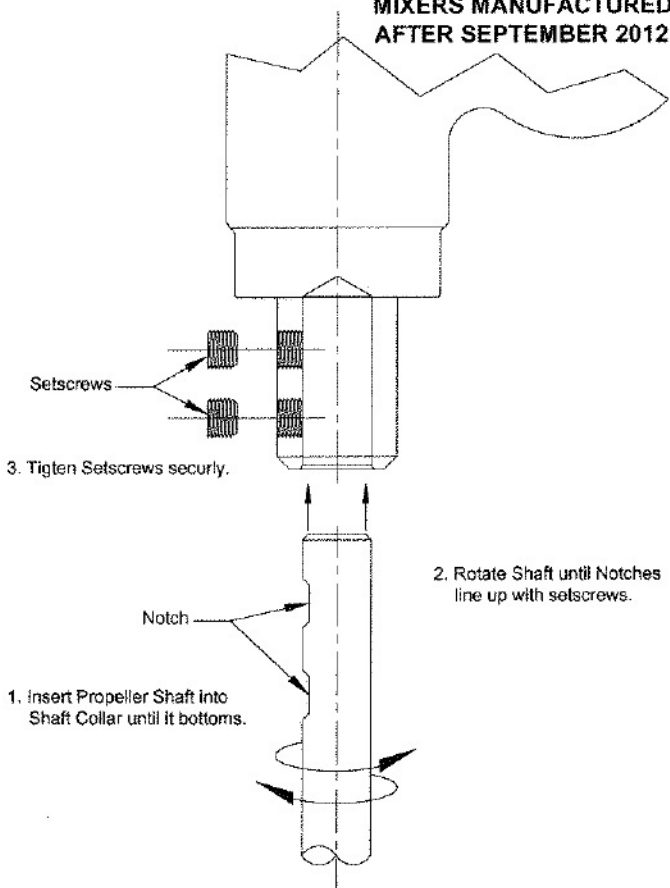

SHAFT INSTALLATION DIAGRAM
(Refer to Section D.)

SHAFT AND PROPELLER PARTS LIST
For Series JG, JD Clamp Mount Model Mixers
And Series JGR and JDR Angle Riser Mount Model Mixers
(Refer to Drawing on Page 8)

| ITEM NUMBER | ITEM DESCRIPTION | QTY. | MODEL JG2.0- JG6.1 | MODEL JG7.1 - JG8.1 | MODEL JG9.1 |
|---------------------------------------|---------------------------------------|------|--------------------------------------|--------------------------------------|--------------------------------------|
| 39 | Shaft 3/4" dia. x 30" lg. | 1 | 004396 | | |
| | Shaft 3/4" dia. x 40" lg. | 1 | 004397 | | |
| | Shaft 3/4" dia. x 36" lg. | 1 | 003084 | | |
| | Shaft 3/4" dia. x 48" lg. | 1 | 003075 | | |
| | Shaft 3/4" dia. x 60" lg. | 1 | 003076 | | |
| | Shaft 1" dia. x 48" lg. | 1 | 004398 | | |
| | Shaft 1" dia. x 60" lg. | 1 | 003071 | | |
| | Shaft 1" dia. x 72" lg. | 1 | 003072 | | |
| | Shaft 1-1/4" dia. x 60" lg. | 1 | | 003073 | 003073 |
| | Shaft 1-1/4" dia. x 72" lg. | 1 | | 003074 | 003074 |
| 40 | Prop 5 x 5, 3/4" Bore, P/N 100383 | A/R | As Required Per Application | As Required Per Application | As Required Per Application |
| | Prop 4 x 4, 3/4" Bore, P/N 100384 | | | | |
| | Prop 14 x 14, 1-1/4" Bore, P/N 100385 | | | | |
| | Prop 12 x 12, 1" Bore, P/N 100389 | | | | |
| | Prop 11 x 11, 1" Bore, P/N 100390 | | | | |
| | Prop 6 x 6, 1" Bore, P/N 100392 | | | | |
| | Prop 5 x 5, 1" Bore, P/N 100393 | | | | |
| | Prop 7 x 7, 3/4" Bore, P/N 100394 | | | | |
| | Prop 6 x 6, 3/4" Bore, P/N 100395 | | | | |
| | Prop 5 x 5, 3/4" Bore, P/N 106046 | | | | |
| | Prop 6 x 6, 3/4" Bore, P/N 106043 | | | | |
| | Prop 8 x 8, 3/4" Bore, P/N 106218 | | | | |
| | Prop 10 x 10, 3/4" Bore, P/N 106219 | | | | |
| | Prop 12 x 12, 3/4" Bore, P/N 106220 | | | | |
| | Prop 13 x 13, 3/4" Bore, P/N 106221 | | | | |
| | Prop 13 x 13, 1" Bore, P/N 1 06222 | | | | |
| | Prop 16 x 16, 1-1/4" Bore, P/N 106225 | | | | |
| | Prop 11 x 11, 3/4" Bore, P/N 106229 | | | | |
| Prop 7 x 7, 1" Bore, P/N 106232 | | | | | |
| Prop 15 x 15, 1-1/4" Bore, P/N 106344 | | | | | |

PARTS LIST
For Series JG Clamp Mount Model Mixers
(Refer to Drawing on Page 8)

| ITEM NUMBER | ITEM DESCRIPTION | QTY. | MODEL JG2.0 - JG6.1 | MODEL JG7.1 - JG8.4 | MODEL JG9.1 |
|-------------|-------------------------------------|------|---------------------|---------------------|-------------|
| 1 | Mixer Gearbox - Body | 1 | 003161 | 003053 | 003053 |
| 2 | Drive Screw | 1 | 100370 | N/A | N/A |
| 3 | Clamp Button | 1 | 000476 | N/A | N/A |
| 4 | Stud | 1 | 002683 | N/A | N/A |
| 5 | Mounting Clamp | 1 | 003146 | N/A | N/A |
| 6 | Hex Head Cap Screw or Stud | 1 | 100397 | N/A | N/A |
| 7* | Flat Washer | 1 | 100369 | N/A | N/A |
| 8 | Pivot Washer | 1 | 100509 | N/A | N/A |
| 9 | Flat Washer | 1 | 106833 | N/A | N/A |
| 10 | Hex Nut | 1 | WA170583 | N/A | N/A |
| 11 | Helical Pinion | 1 | 003143 | 003141 | 003054 |
| 12 | Hex Head Cap Screw | 4 | 100216 | 100216 | 100216 |
| 13 | Lock Washer | 4 | 100217 | 100217 | 100217 |
| 14 | Hex Head Cap Screw | 6 | 106748 | 106748 | 106748 |
| 15 | Lock Washer | 6 | 100075 | 100075 | 100075 |
| 16 | Motor Gasket | 1 | 106097 | 106097 | 106097 |
| 17 | Set Screw | 1 | 105159 | 105159 | 105159 |
| 18 | Key | 1 | 003060 | 106589 | 003060 |
| 19 | Dowel Pin | 2 | 100351 | 100579 | 100579 |
| 20 | Retaining Ring | 1 | 106594 | 106496 | 106496 |
| 21 | Motor Midplate | 1 | 003148 | 003147 | 003057 |
| 22 | Key | 1 | 100110 | 100110 | 100110 |
| 23 | Midplate Gasket | 1 | 106507 | 106494 | 106494 |
| 24 | Helical Gear | 1 | 003144 | 003142 | 003055 |
| 25 | Seal | 1 | 106586 | 106542 | 106542 |
| 26 | Retaining Ring | 1 | 106592 | 106562 | 106562 |
| 27* | Ball Bearing | 1 | 106180 | 106495 | 106495 |
| 28 | Shaft Adapter, 3/4" dia. | 1 | 003406 | N/A | N/A |
| | Shaft Adapter, 1" dia. | 1 | 003407 | 003059 | N/A |
| | Shaft Adapter, 1-1/4" dia. | 1 | N/A | 003058 | 003058 |
| 29 | Retaining Ring | 2 | 106593 | 106497 | 106497 |
| 30* | Ball Bearing | 1 | 106588 | 106564 | 106564 |
| 31 | Felt Wiper Seal | 1 | 106502 | 106488 | 106488 |
| 32 | Setscrew | 2 | 104618 | 104618 | 104618 |
| 33 | Shaft Adapter Reducer, 1" to 3/4" | 1 | 004647 | N/A | N/A |
| | Shaft Adapter Reducer, 1-1/4" to 1" | 1 | N/A | 004648 | N/A |

*Recommended Spare Parts

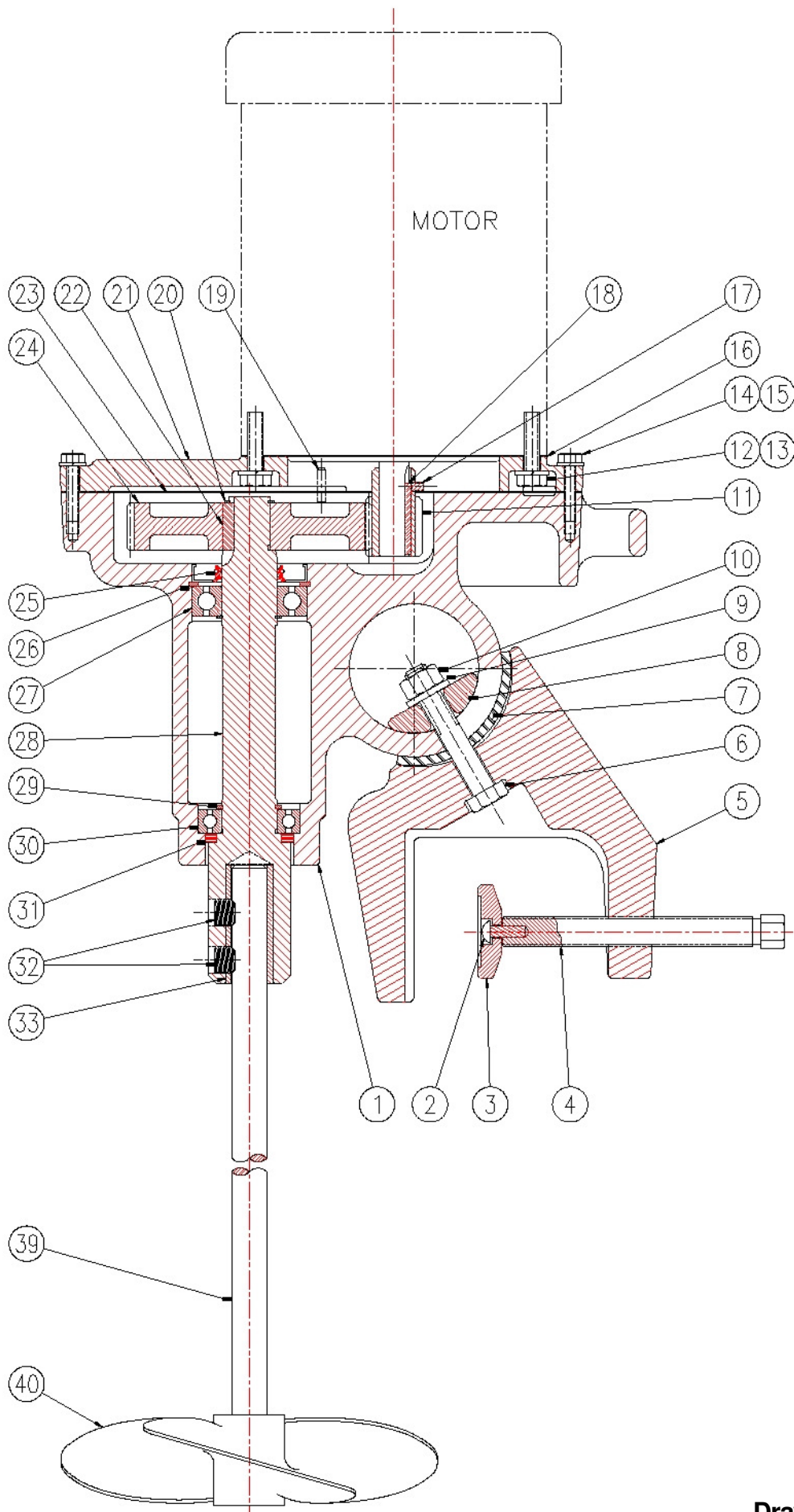

Mixer Model JG
Drawing No. S00070

PARTS LIST
For Series JD Clamp Mount Model Mixers
(Refer to Drawing on Page 10)

| ITEM NUMBER | ITEM DESCRIPTION | QTY. | MODEL JD2.0 - JG6.1 | MODEL JD7.1 - JD7.4 |
|-------------|-------------------------------------|------|---------------------|---------------------|
| 1 | Mixer Gearbox - Body | 1 | 003161 | 003053 |
| 2 | Drive Screw | 1 | 100370 | 100370 |
| 3 | Clamp Button | 1 | 000476 | 000476 |
| 4 | Stud | 1 | 002683 | 002683 |
| 5 | Mounting Clamp | 1 | 003146 | 002682 |
| 6 | Hex Head Cap Screw or Stud | 1 | 100397 | 106387 |
| 7* | Flat Washer | 1 | 100369 | 100369 |
| 8 | Pivot Washer | 1 | 100509 | 106074 |
| 9 | Flat Washer | 1 | 106833 | 100051 |
| 10 | Hex Nut | 1 | WA170583 | 108518 |
| 13 | Lock Washer | 4 | 100217 | 100217 |
| 14 | Hex Head Cap Screw | 6 | 106748 | 106748 |
| 15 | Lock Washer | 6 | 100075 | 100075 |
| 16 | Motor Gasket | 1 | 106097 | 106097 |
| 19 | Dowel Pin | 2 | 100351 | 100579 |
| 21 | Motor Midplate | 1 | 003148 | 003057 |
| 22 | Key | 1 | 100110 | 100110 |
| 23 | Midplate Gasket | 1 | 106507 | 106494 |
| 25 | Seal | 1 | 106586 | 106542 |
| 26 | Retaining Ring | 1 | 106592 | 106562 |
| 27* | Ball Bearing | 1 | 106180 | 106495 |
| 28 | Shaft Adapter, 3/4" dia. | 1 | 003406 | N/A |
| | Shaft Adapter, 1" dia. | 1 | 003407 | 003058 |
| | Shaft Adapter, 1-1/4" dia. | 1 | N/A | N/A |
| 29 | Retaining Ring | 2 | 106593 | 106497 |
| 30* | Ball Bearing | 1 | 106588 | 106564 |
| 31 | Felt Wiper Seal | 1 | 106502 | 106488 |
| 32 | Setscrew | 2 | 104618 | 104618 |
| 33 | Shaft Adapter Reducer, 1" to 3/4" | 1 | 004647 | N/A |
| | Shaft Adapter Reducer, 1-1/4" to 1" | 1 | N/A | 004648 |
| 34 | Hex Head Cap Screw | 4 | 108338 | 108338 |
| 35 | Key | 1 | 100218 | 100218 |
| 36 | Motor Extension | 1 | 003197 | 003197 |
| 37 | Coupling | 1 | 106664 | 106640 |

*Recommended Spare Parts

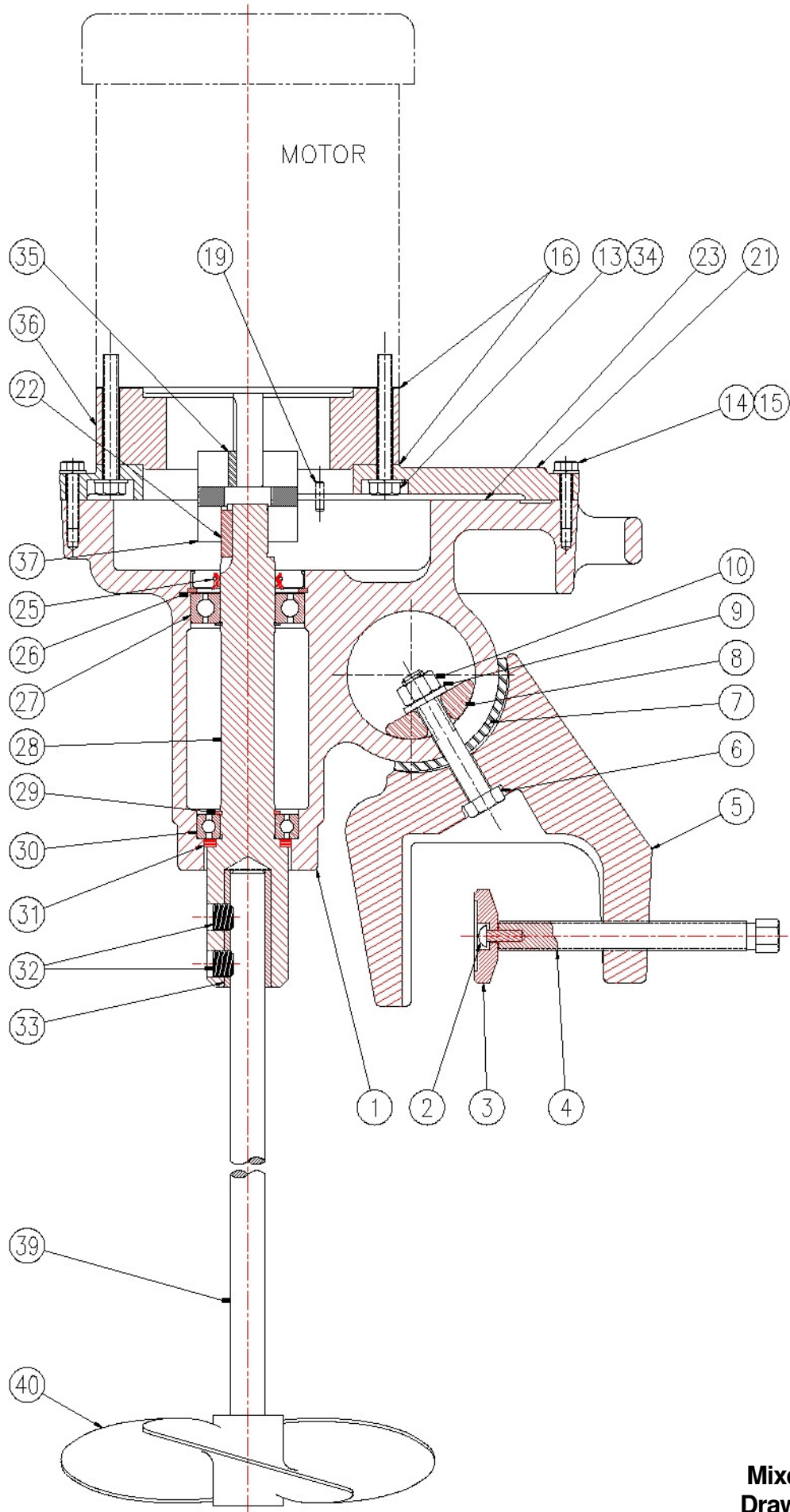

Mixer Model JD
Drawing No. S00072

PARTS LIST
For Series JGR and JDR Angle Riser Mount Model Mixers

NOTE: All parts in JGR and JDR Mixers are the same as JG or JD Mixers except mounting clamps. JGR and JDR Mixers do not use items 2 to 10 including items on parts list (Refer to pages 7 and 9). JGR and JDR do use parts listed below for Angle Riser Mount.

| ITEM NUMBER | PART NUMBER | ITEM DESCRIPTION | QTY. PER ASSEMBLY | |
|-------------|-------------|----------------------------|-------------------|----------|
| | | | JGR QTY. | JDR QTY. |
| 1 ** | 003161 | Mixer Gearbox - Body | 1 | 1 |
| 41 | 106268 | Hex Head Cap Screw | 4 | 4 |
| 42 ** | 106704 | Hex Head Cap Screw | 4 | 4 |
| | 106996 | Socket Head Cap Screw | 8 | 8 |
| 43 ** | 106281 | Angle Riser Midplate | 1 | 1 |
| | 106809 | Angle Riser Midplate | 1 | 1 |
| 44 ** | 100457 | Lock Washer | 4 | 4 |
| | 108592 | Internal Tooth Lock Washer | 8 | 8 |
| 45 | 002794 | Angle Riser (Right Side) | 1 | 1 |
| 46 | 002795 | Angle Riser (Left Side) | 1 | 1 |
| 47 | 100105 | Lock Washer | 4 | 4 |
| 48 | 106267 | Hex Nut | 4 | 4 |

**These Parts are for JGR/JDR-2.0-JGR/JDR 6.1 Only.

INSTALLATION:

1. Remove the Mixer and Angle Riser Unit (A.R.U.) from their shipping cartons.
2. Install assembled A.R.U. onto tank, see page 3, for mounting instruction, and secure in place.
3. Place Mixer onto A.R.U. and secure with hardware provided (42, 44).
4. Insert Shaft into Mixer Shaft Collar and secure as described on page 5 in Section "0" of the Operating and Instruction Manual of Series JG and JD Mixers.

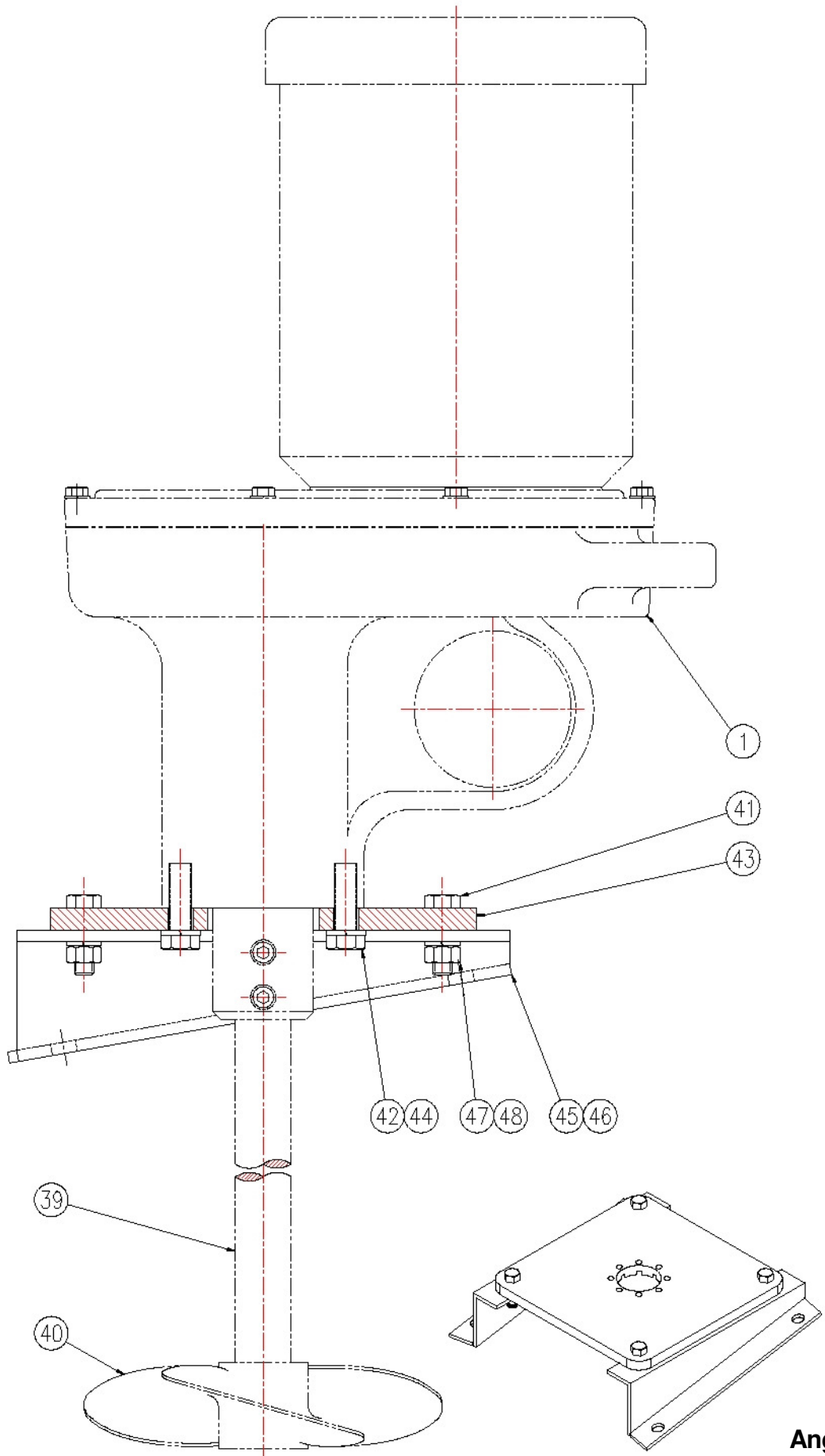

**Angle Riser Mount
Drawing No. S00051**

FLANGE MOUNTING MIXER ADDENDUM TO OPERATING AND INSTRUCTION MANUAL FOR SERIES JG AND JD MIXERS

PARTS LIST For Series JGF and JDF Stuffing-Box Model Mixers

NOTE: All parts in JGF and JDF Mixers are the same as JG or JD Mixers except mounting clamps. JGF and JDF Mixers do not use items 2 to 10 including items on parts list (Refer to pages 7 and 9). JGF and JDF do use Parts listed below for Flange Mount.

| ITEM NO. | PART NO. | ITEM DESCRIPTION | QTY. |
|----------|----------|---|------|
| 1** | 003161 | Mixer Gearbox - Body | 1 |
| 42 | 106704 | Hex Head Cap Screw 1/2-20 x 1-1/2" lg. | 4 |
| ** | 106996 | Socket Head Cap Screw 1/4-20 x 3/4" lg. | 8 |
| 44 | 100457 | 1/2" Lock Washer | 4 |
| ** | 108592 | 1/4" Internal Tooth Lock Washer | 8 |
| 47 | 100105 | 7/16" Lock Washer | 16 |
| 48 | 106267 | 7/16-14 Hex Nut | 8 |
| 49 | 106619 | Hex Head Cap Screw 7/16-14 x 1-3/4" lg. | 8 |
| 50** | 003270 | Mixer Spacer Adapter | 1 |
| | 003271 | Mixer Spacer Adapter | 1 |
| 51 | 003260 | Stuffing-Box Spacer | 1 |
| 52 | 108180 | 3/8-16 Hex Nut with Nylock | 4 |
| 53** | 003265 | 1" dia. Shaft, Sealing Bushing | 1 |
| | 003266 | 1-1/4" dia. Shaft, Sealing Bushing | 1 |
| ** | 003274 | 3/4" dia. Shaft, Sealing Bushing | 1 |
| 54 | 106620 | 3/8-16 x 3-1/2" lg. Stud | 4 |
| 55 | 100036 | Grease Filling | 1 |
| 56 | 100104 | Hex Head Cap Screw 7/16-14 x 1-1/4" lg. | 8 |
| *57** | 003261 | 1" dia. Shaft, Lantern Ring | 1 |
| | 003262 | 1-1/4" dia. Shaft, Lantern Ring | 1 |
| ** | 003273 | 3/4" dia. Shaft, Lantern Ring | 1 |

*Recommended Spare Parts.

**These Parts are for Models JGF JDF-2.0 through JGF/JDF-6.1 Only.
Item 58 available in 316SS & Carbon Steel.

| ITEM NO. | PART NO. | ITEM DESCRIPTION | QTY. |
|----------|----------|--|------|
| 58** | | 1" dia. Shaft, 6" Flange Assembly | 1 |
| ** | | 1" dia. Shaft, 8" Flange Assembly | 1 |
| ** | | 1" dia. Shaft, 10" Flange Assembly | 1 |
| ** | | 1" dia. Shaft, 12" Flange Assembly | 1 |
| ** | | 1" dia. Shaft, 14" Flange Assembly | 1 |
| | | 1-1/4" dia. Shaft, 6" Flange Assembly | 1 |
| | | 1-1/4" dia. Shaft, 8" Flange Assembly | 1 |
| | | 1-1/4" dia. Shaft, 10" Flange Assembly | 1 |
| | | 1-1/4" dia. Shaft, 12" Flange Assembly | 1 |
| | | 1-1/4" dia. Shaft, 14" Flange Assembly | 1 |
| ** | | 3/4" dia. Shaft, 6" Flange Assembly | 1 |
| ** | | 3/4" dia. Shaft, 8" Flange Assembly | 1 |
| ** | | 3/4" dia. Shaft, 10" Flange Assembly | 1 |
| ** | | 3/4" dia. Shaft, 12" Flange Assembly | 1 |
| ** | | 3/4" dia. Shaft, 14" Flange Assembly | 1 |
| 59** | 003267 | 1" dia. Shaft, Packing | 5 |
| | 003268 | 1-1/4" dia. Shaft, Packing | 5 |
| ** | 003269 | 3/4" dia. Shaft, Packing | 5 |
| 60 | 003272 | Mixer Window Screen | 2 |
| 61 | 106621 | #8-32 x 3/8 lg. Pan Head Screw | 8 |
| 62** | 106614 | 1" dia. Shaft Collar | 1 |
| | 106615 | 1-1/4" dia. Shaft Collar | 1 |
| ** | 106811 | 3/4" dia. Shaft Collar | 1 |
| 63 | 101208 | 1/4" x 3/4" lg. Dowel Pin | 2 |

INSTALLATION:

1. Remove the Mixer and Flange Mounting Unit (F.M.U.) from their shipping cartons.
2. Remove the (2) Window Screens [60] by unscrewing (8) Screws [61].
3. Remove Mixer Spacer Adapter [50] from the F.M.U.
4. Place the Propellers on the end of the shaft WITHOUT THE NOTCH and then insert into the empty tank.
5. Lubricate the end of the Shaft WITH THE NOTCH and insert through the Orifice of the F.M.U. to protrude approximately 2-1/2", taking care as not to mar the surface of the propeller shaft.
6. To prevent the Shaft from falling into the tank, place the Shaft Collar [62] on the Shaft and secure with a Socket Head Screw and Hex Wrench provided.
7. Install assembled F.M.U. onto Tank and secure in place, make sure that there is free access to the Stuffing Chamber through the windows.
8. Fasten Mixer Spacer [50] with Screws [42] and Lock Washers [44] onto Mixer.
9. Place Mixer assembled with Mixer Spacer Adapter [50] onto F.M.U. and secure with Hardware provided [47, 48, 49].
10. Insert Shaft into Mixer Shaft Collar and secure as described on pg. 5 in Section D, of the Operating and Instruction Manual of Series JG & JD Mixers.
11. Pack Stuffing Chamber with Grease through Grease Fitting [55].
12. Adjust the Packing Pressure with Sealing Bushing [53] by applying approximately 10 in. lbs. to the (4) 3/8-16 Hex Nuts (tightened uniformly).
13. Replace Window Screens [60] before operating Mixer.

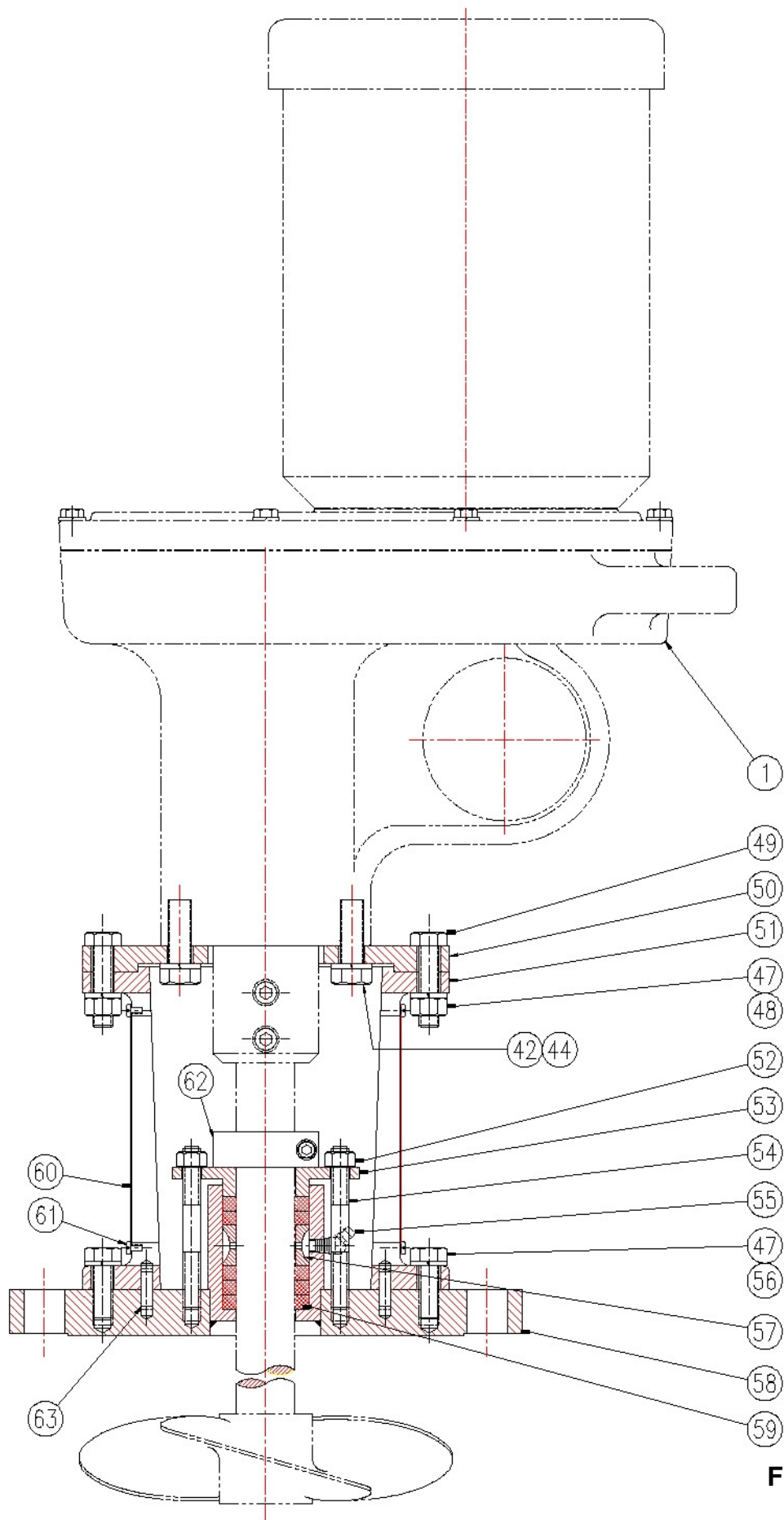

**Flange Mounting Unit
Drawing No. S00073**



MATERIAL SAFETY DATA SHEET

1. Product and Company Identification

Material name Termalene Heavy Duty Construction Grease
Product Code 72560
Version # 1.1
Revision date 05-23-2012
Synonym(s) Termalene EP 2C Ex Tacky
Manufacturer information Bel-Ray Company, Inc.
P.O. Box 526
Farmingdale, NJ 07727
United States of America
+1 732 938 2421
CHEMTREC: +1 703-527-3887 (outside USA)
CHEMTREC: 800-424-9300 (USA)

2. Hazards Identification

Emergency overview CAUTION
Harmful in contact with eyes. Prolonged exposure may cause chronic effects.

OSHA regulatory status This product is considered hazardous under 29 CFR 1910.1200 (Hazard Communication).

Potential health effects

Routes of exposure Inhalation. Ingestion. Skin contact. Eye contact.

Eyes Eye contact may result in corneal injury. Contact may irritate or burn eyes. Do not get this material in contact with eyes.

Skin Frequent or prolonged contact may defat and dry the skin, leading to discomfort and dermatitis. Avoid contact with the skin.

Inhalation Avoid breathing dust/fume/gas/mist/vapors/spray.

Ingestion Components of the product may be absorbed into the body by ingestion. Do not ingest.

Target organs Eyes. RESPIRATORY SYSTEM. Skin.

Chronic effects Conjunctiva. Frequent or prolonged contact may defat and dry the skin, leading to discomfort and dermatitis.

Signs and symptoms Corneal damage. Conjunctivitis. Defatting of the skin. Skin irritation. Rash.

Potential environmental effects Components of this product are hazardous to aquatic life. May cause long-term adverse effects in the environment.

3. Composition / Information on Ingredients

| Components | CAS # | Percent |
|---|------------|----------|
| Distillates (petroleum), Hydrotreated Heavy Naphthenic | 64742-52-5 | 0 - 90 |
| Distillates (petroleum), Hydrotreated Heavy Paraffinic | 64742-54-7 | 0 - 90 |
| Distillates (petroleum), Solvent-refined Heavy Paraffinic | 64741-88-4 | 0 - 90 |
| Lubricating Oils (petroleum), Hydrotreated Spent | 64742-58-1 | 0 - 90 |
| White Mineral Oil (petroleum) | 8042-47-5 | 0 - 90 |
| Aluminum, (benzoato-o,o)hydroxy(octadecanoato-o,o)- | 54326-11-3 | 2.5 - 10 |
| Antimony Tris[o,o-dipropyl] Tris(dithiophosphate) | 15874-48-3 | 1 - 2.5 |
| Other components below reportable levels | | 2.5 - 10 |

Composition comments IP 346: < 3.0% DMSO extract for all base oil substances.

4. First Aid Measures

First aid procedures

- Eye contact** Immediately flush eyes with plenty of water for at least 15 minutes. Remove contact lenses, if present and easy to do. Continue rinsing. Get medical attention immediately.
- Skin contact** Wash off with warm water and soap. Get medical attention if irritation develops and persists.
- Inhalation** If breathing is difficult, remove to fresh air and keep at rest in a position comfortable for breathing. Call a physician if symptoms develop or persist.
- Ingestion** Rinse mouth thoroughly. Do not induce vomiting. If ingestion of a large amount does occur, call a poison control center immediately. Never give liquid to an unconscious person.

Notes to physician

Symptoms may be delayed.

General advice

Ensure that medical personnel are aware of the material(s) involved, and take precautions to protect themselves.

5. Fire Fighting Measures

Flammable properties Not flammable by OSHA criteria. Not combustible by OSHA criteria.

Extinguishing media

Suitable extinguishing media Water fog. Foam. Dry powder. Carbon dioxide (CO₂).

Unsuitable extinguishing media Water. Do not use water jet as an extinguisher, as this will spread the fire.

Protection of firefighters

Protective equipment and precautions for firefighters Wear suitable protective equipment.

Fire fighting equipment/instructions Move containers from fire area if you can do so without risk.

Hazardous combustion products Carbon monoxide and carbon dioxide.

6. Accidental Release Measures

Personal precautions Keep unnecessary personnel away. Do not touch damaged containers or spilled material unless wearing appropriate protective clothing. Keep people away from and upwind of spill/leak. Keep upwind. Keep out of low areas. Ventilate closed spaces before entering them.

Environmental precautions Prevent further leakage or spillage if safe to do so. Do not contaminate water.

Methods for containment ELIMINATE all ignition sources (no smoking, flares, sparks or flames in immediate area). Stop the flow of material, if this is without risk. Dike the spilled material, where this is possible. Use water spray to reduce vapors or divert vapor cloud drift. Prevent entry into waterways, sewer, basements or confined areas.

Methods for cleaning up Should not be released into the environment. This product is miscible in water.

Large Spills: Stop the flow of material, if this is without risk. Dike the spilled material, where this is possible. Cover with plastic sheet to prevent spreading. Absorb in vermiculite, dry sand or earth and place into containers. Following product recovery, flush area with water.

Small Spills: Wipe up with absorbent material (e.g. cloth, fleece). Clean surface thoroughly to remove residual contamination.

Never return spills in original containers for re-use. For waste disposal, see section 13 of the MSDS.

7. Handling and Storage

Handling

DO NOT handle, store or open near an open flame, sources of heat or sources of ignition. Protect material from direct sunlight. Do not get this material in contact with eyes. Avoid contact with skin. Avoid prolonged exposure. Avoid release to the environment. Hydrogen sulfide (H₂S) may be given off when this material is heated. Do not depend on sense of smell for warning.

Storage

Class IIIB Combustible Liquid.

Keep away from heat, sparks and open flame. Store in a well-ventilated place. Keep container tightly closed. Keep away from food, drink and animal feedingstuffs. Keep out of the reach of children. Use care in handling/storage.

8. Exposure Controls / Personal Protection**Occupational exposure limits**

| ACGIH Components | Type | Value | Form |
|---|-------------|---------------------|---------------------|
| Distillates (petroleum), Hydrotreated Heavy Naphthenic (64742-52-5) | TWA | 5 mg/m ³ | Inhalable Fraction. |

| US. ACGIH Threshold Limit Values | | | |
|--|-------------|-----------------------|----------------------|
| Components | Type | Value | Form |
| Aluminum, (benzoato-o,o)hydroxy(octadecanoato-o,o)- (54326-11-3) | TWA | 1 mg/m ³ | Respirable fraction. |
| Antimony Tris[o,o-dipropyl] Tris(dithiophosphate) (15874-48-3) | TWA | 0.5 mg/m ³ | |
| White Mineral Oil (petroleum) (8042-47-5) | TWA | 5 mg/m ³ | Inhalable fraction. |

| US. OSHA Table Z-1 Limits for Air Contaminants (29 CFR 1910.1000) | | | |
|--|-------------|--|-------------|
| Components | Type | Value | Form |
| Antimony Tris[o,o-dipropyl] Tris(dithiophosphate) (15874-48-3) | PEL | 0.5 mg/m ³ | |
| Distillates (petroleum), Hydrotreated Heavy Naphthenic (64742-52-5) | PEL | 5 mg/m ³ | Mist. |
| Distillates (petroleum), Hydrotreated Heavy Paraffinic (64742-54-7) | PEL | 2000 mg/m ³ 500 ppm 5 mg/m ³ | Mist. |
| Distillates (petroleum), Solvent-refined Heavy Paraffinic (64741-88-4) | PEL | 5 mg/m ³ | Mist. |
| Lubricating Oils (petroleum), Hydrotreated Spent (64742-58-1) | PEL | 2000 mg/m ³ 500 ppm 5 mg/m ³ | Mist. |
| White Mineral Oil (petroleum) (8042-47-5) | PEL | 5 mg/m ³ | Mist. |

Exposure guidelines

Occupational Exposure Limits are not relevant to the current physical form of the product.

Personal protective equipment**Eye / face protection**

Do not get in eyes. Chemical goggles are recommended. Eye wash fountain is recommended.

Skin protection

Wear appropriate chemical resistant clothing. Chemical resistant gloves.

Respiratory protection

Wear positive pressure self-contained breathing apparatus (SCBA).

General hygiene considerations

Do not get in eyes. Avoid contact with skin. Keep away from food and drink. Handle in accordance with good industrial hygiene and safety practice.

9. Physical & Chemical Properties

| | |
|-------------------|-----------|
| Appearance | Gel. |
| Form | Grease |
| Color | Red. |
| Odor | Petroleum |

| | |
|---|--|
| Odor threshold | Not available. pH Not available. |
| Vapor pressure | 0 hPa estimated |
| Density | 875 kg/m ³ |
| Vapor density | Not available. |
| Boiling point | 680 °F (360 °C) estimated |
| Melting point/Freezing point | 156.74 °F (69.3 °C) estimated |
| Solubility (water) | Negligible |
| Solubility (other) | Oil |
| Specific gravity | 0.88 |
| Relative density | Not available. |
| Flash point | 437 °F (225 °C) Cleveland Open Cup |
| Flammability limits in air, upper, % by volume | Not available. |
| Flammability limits in air, lower, % by volume | Not available. |
| Auto-ignition temperature | 500 °F (260 °C) estimated |
| VOC | 0.14 % estimated |
| Viscosity | 269 cSt (Base Oil) |
| Percent volatile | 0.14 % estimated |
| Other data | |
| Drop point | > 500 °F (> 260 °C) |
| Flammability class | Combustible IIIB estimated |
| Flash point class | Combustible IIIB |
| Viscosity temperature | 104 °F (40 °C) |

10. Chemical Stability & Reactivity Information

| | |
|---|---|
| Chemical stability | Material is stable under normal conditions. |
| Conditions to avoid | Heat, flames and sparks. Avoid temperatures exceeding the flash point. |
| Incompatible materials | Not available. |
| Hazardous decomposition products | Toxic gas. At thermal decomposition temperatures, carbon monoxide and carbon dioxide. Hydrogen sulfide. Mercaptans. |

11. Toxicological Information

Toxicological data

Product

Test Results

Termalene Heavy Duty Construction Grease (Mixture)

Acute Oral LD50 Rat: 343.94 g/kg estimated

Acute Other LD50 Mouse: 1725.62 mg/kg estimated

Acute Other LD50 Rat: 1432.53 mg/kg estimated

Local effects

Components of the product may be absorbed into the body through the skin. Contact may irritate or burn eyes.

Chronic effects

Hazardous by OSHA criteria. Prolonged exposure may cause chronic effects.

Carcinogenicity

This product is not considered to be a carcinogen by IARC, ACGIH, NTP, or OSHA.

ACGIH Carcinogens

Aluminum, (benzoato-o,o)hydroxy(octadecanoato-o,o)-
ALUMINUM METAL AND INSOLUBLE COMPOUNDS,
RESPIRABLE FRACTION (CAS 54326-11-3) A4 Not classifiable as a human carcinogen.

Distillates (petroleum), Hydrotreated Heavy Naphthenic
MINERAL OIL, EXCLUDING METAL WORKING FLUIDS,
PURE, HIGHLY AND SEVERELY REFINED, INHALABLE
FRACTION (CAS 64742-52-5) A4 Not classifiable as a human carcinogen.

Distillates (petroleum), Solvent-refined Heavy Paraffinic MINERAL OIL, EXCLUDING METAL WORKING FLUIDS, PURE, HIGHLY AND SEVERELY REFINED, INHALABLE FRACTION (CAS 64741-88-4) A4 Not classifiable as a human carcinogen.

White Mineral Oil (petroleum) MINERAL OIL, EXCLUDING METAL WORKING FLUIDS, PURE, HIGHLY AND SEVERELY REFINED, INHALABLE FRACTION (CAS 8042-47-5) A4 Not classifiable as a human carcinogen.

IARC Monographs. Overall Evaluation of Carcinogenicity

MINERAL OILS, HIGHLY-REFINED (CAS 8042-47-5) 3 Not classifiable as to carcinogenicity to humans.

12. Ecological Information

Ecotoxicological data

Product

Test Results

Termalene Heavy Duty Construction Grease (Mixture)

EC50 Daphnia: 72954.55 mg/l 48 hours estimated

* Estimates for product may be based on additional component data not shown.

Ecotoxicity

Components of this product are hazardous to aquatic life.

Environmental effects

Harmful to aquatic organisms. An environmental hazard cannot be excluded in the event of unprofessional handling or disposal.

Persistence and degradability

Not available.

13. Disposal Considerations

Waste codes

D005: Waste Barium

Disposal instructions

Collect and reclaim or dispose in sealed containers at licensed waste disposal site. Incinerate the material under controlled conditions in an approved incinerator. Do not allow this material to drain into sewers/water supplies. Dispose in accordance with all applicable regulations.

Contaminated packaging

Empty containers should be taken to an approved waste handling site for recycling or disposal.

14. Transport Information

DOT

Not regulated as dangerous goods.

IATA

Not regulated as dangerous goods.

IMDG

Not regulated as dangerous goods.

15. Regulatory Information

US federal regulations

This product is a "Hazardous Chemical" as defined by the OSHA Hazard Communication Standard 29 CFR 1910.1200.
One or more components are not listed on TSCA.

US EPCRA (SARA Title III) Section 313 - Toxic Chemical: De minimis concentration

Antimony Tris[o,o-dipropyl] Tris(dithiophosphate) (CAS 15874-48-3) 1.0 % N010

US EPCRA (SARA Title III) Section 313 - Toxic Chemical: Listed substance

Antimony Tris[o,o-dipropyl] Tris(dithiophosphate) (CAS 15874-48-3) Listed. N010

CERCLA (Superfund) reportable quantity

None

Superfund Amendments and Reauthorization Act of 1986 (SARA)

Hazard categories

Immediate Hazard - Yes
Delayed Hazard - Yes
Fire Hazard - No
Pressure Hazard - No
Reactivity Hazard - No

Section 302 extremely hazardous substance

No

Section 311 hazardous chemical Yes
Clean Water Act (CWA) Hazardous substance

State regulations

US - California Proposition 65 - CRT: Listed date/Carcinogenic substance

ETHYLBENZENE (CAS 100-41-4) Listed: June 11, 2004 Carcinogenic.
TITANIUM DIOXIDE (AIRBORNE, UNBOUND PARTICLES OF RESPIRABLE SIZE) (CAS 13463-67-7) Listed: September 2, 2011 Carcinogenic.

US - New Jersey RTK - Substances: Listed substance

Antimony Tris[o,o-dipropyl] Tris(dithiophosphate) (CAS 15874-48-3) Listed.
Distillates (petroleum), Hydrotreated Heavy Naphthenic (CAS 64742-52-5) Listed.
Distillates (petroleum), Hydrotreated Heavy Paraffinic (CAS 64742-54-7) Listed.
Distillates (petroleum), Solvent-refined Heavy Paraffinic (CAS 64741-88-4) Listed.
Lubricating Oils (petroleum), Hydrotreated Spent (CAS 64742-58-1) Listed.

US - Pennsylvania RTK - Hazardous Substances: Listed substance

Distillates (petroleum), Hydrotreated Heavy Naphthenic (CAS 64742-52-5) Listed.
Distillates (petroleum), Hydrotreated Heavy Paraffinic (CAS 64742-54-7) Listed.
Lubricating Oils (petroleum), Hydrotreated Spent (CAS 64742-58-1) Listed.
White Mineral Oil (petroleum) (CAS 8042-47-5) Listed.

16. Other Information

Further information HMIS® is a registered trade and service mark of the NPCA.

HMIS® ratings Health: 1*
Flammability: 1
Physical hazard: 0

NFPA ratings Health: 1
Flammability: 1
Instability: 0

Disclaimer Bel-Ray Company cannot anticipate all conditions under which this information and its product, or the products of other manufacturers in combination with its product, may be used. It is the user's responsibility to ensure safe conditions for handling, storage and disposal of the product, and to assume liability for loss, injury, damage or expense due to improper use.

Issue date 05-23-2012

This data sheet contains changes from the previous version in section(s): Product and Company Identification: Bel Ray Custom Labels
Hazards Identification: Emergency overview
Composition / Information on Ingredients: Ingredients
Composition / Information on Ingredients: Composition comments
Handling and Storage: Handling
Physical & Chemical Properties: Multiple Properties
Toxicological Information: Acute effects

MAINTENANCE LOG

Mixer Model _____

Serial # _____

Shaft Diameter and Length _____

Mixer RPM _____

Propeller Diameter _____

Spare Parts Kit #107781 for JG/JD 2.X to 6.X MIXER or #107782 for 7.X to 9.X MIXER (For Mixers using Pin Bolt)

Spare Parts Kit #104619 for JG/JD 2.X to 6.X MIXER or #104652 for JG/JD 7.X to 9.X MIXER (For Mixers using Setscrews)

NEPTUNE CHEMICAL PUMP CO. Tel.: 215-699-8700 • FAX: 215-699-0370

| DATE | SERVICED BY | MAINTENANCE PERFORMED |
|------|-------------|-----------------------|
| | | |
| | | |
| | | |
| | | |
| | | |
| | | |
| | | |
| | | |
| | | |
| | | |
| | | |
| | | |
| | | |
| | | |
| | | |
| | | |
| | | |
| | | |
| | | |
| | | |
| | | |