

Reading Technologies, Inc.

*Advanced Air System Technology™*



# Why RTi?

## Superior Engineering. Unique Inverse-Flow™ Filter Technology.

Let's take a look at  
RTi's efficient  
and reliable approach:

- 1 Centrifugal Spinning**  
Water, dirt, & oil contaminants are spun in a downward circular motion through the air. The spinning action forces heavy particles outward—towards the drain.
- 2 Inverse-Flow™**  
RTi's Inverse-Flow™ process creates a condition where the air, spinning in a downward circular motion, changes direction 180° and begins to flow vertically upward. Contaminants are not capable of reversing direction & must separate from the air flow. This process prevents re-entrainment of contamination, which can occur in other filter systems.
- 3 Stainless Steel Element**  
Pre-cleaned air enters a filter media composed of finely interwoven stainless steel mesh wires. The striated surface efficiently holds aerosols and liquid droplets, which then fall into the drain area. Filtration to 3.0 micron.
- 4 Final Filter Media**  
Composed of interwoven cotton, polyester and stainless steel. Filter captures excess sub-micron water droplets. Cotton holds the water particles & allows them to re-enter the air stream as harmless vapor. Filtration to 1.0 micron.
- 5 Bowl & Drain Options**  
Bowls—metal or polycarbonate bowl with metal guard.  
Drains—automatic float, manual, or electronic options.

**Reading Technologies, Inc.** has been at the forefront of **advanced air system technology** since 1986. Our innovations include compressor room desiccant & refrigerated dryers, main line separators/coalescers, point-of-use dryers, and filter, regulator and lubricator units.

The RTi brand prides itself with providing **clean, dry air**. Have specific requests? We build around your custom needs. Call us to find out more: (800) 521-9200

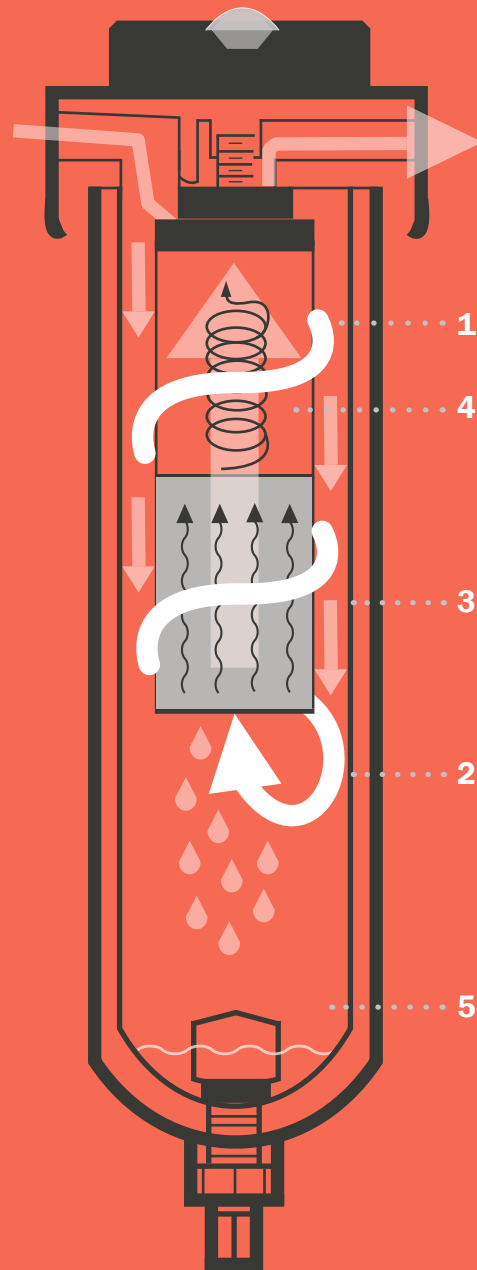

RTi's filter lines are 100% made in the U.S.A.  
All other products are made in the U.S.A. of U.S. and imported parts.  
RTi products are protected by U.S. and international patents/patents pending.  
Eliminex®, Elimimizer®, & Eliminator® are registered trademarks of RTi.  
© 2014 by Reading Technologies, Inc. All rights reserved.

**Efficiency. Productivity. Reliability.**

# Table of Contents

<b>Choosing the Right RTI Filter</b>	a
<b>Choosing the Right System: Schematics</b>	b
<b>Filtration</b>	
Eliminex High Flow Separators	1
Eliminex High Flow Combo Units	6
Eliminizer Filter/Dryers	11
Eliminizer Filter/Dryer Combo Units	14
Coalescers	17
Oil-Extractors	23
Oil Extractor Combo Units	25
Food Grade Units	27
Stainless Steel Units	33
High Pressure Units	37
<b>Dew Point Reduction</b>	
Refrigerated Dryers	39
Point of Use Desiccant Dryers	40
Regenerative Desiccant Dryers (DRAD)	43
<b>Filters, Filter/Regulators &amp; Lubricators</b>	44
<b>Mini Regulators &amp; Gauges</b>	45
<b>Heavy Duty: Regulators</b>	46
<b>Heavy Duty: Filters &amp; Lubricators</b>	47
<b>Compressors</b>	48
<b>Breathing Air Filtration</b>	49
<b>Accessories</b>	
Drains	50
Stands & Display Boards	51
Brackets, Indicators, Couplers & Plugs	52
Replacement Elements	53
Quality Air Test Kit	54

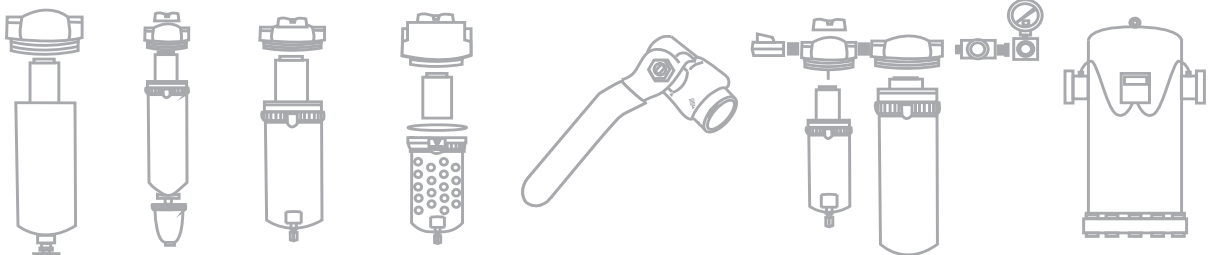

### Eliminex®

*Description:* RTi patented inverse flow filter-dryer with all stainless steel mesh filter packing, excellent water & dirt capture to 3 microns. ISO Class 3 Particulate.

*Port Size Range:* ½" NPT to 6" ASA (150#) Flange

*Flow Range:* 60 scfm to 5500 scfm @ 100 PSI

*Applications:* Generally used in main lines and in heavy duty service where heavy water removal is needed. Also good for outdoor service where freezing temperatures can be encountered.

### Eliminex® Combo

*Description:* (2) stage assembly which combines an Eliminex® (separator/filter) with a high efficiency Coalescer to give superior oil & fine particulate capture, in addition to heavy water removal. 99.99998% efficient at 0.01 micron. ISO Class 1 Particulate/Oil.

*Port Size Range:* ½" NPT to 6" ASA (150#) Flange

*Flow Range:* 60 scfm to 3000 scfm @ 100 PSI

*Applications:* Generally used in main lines and in heavy duty service where heavy water, dirt & oil removal is needed.

### Eliminizer®

*Description:* RTi patented inverse flow filter-dryer with (2) stage filter packing: stainless steel mesh & cotton/polyester. Excellent water & dirt capture to 1 micron. ISO Class 2 Particulate.

*Port Size Range:* ¼" NPT to 1" NPT

*Flow Range:* 20 scfm to 150 scfm @ 100 PSI

*Applications:* Generally used at point of use and in heavy duty service where heavy water & dirt removal is needed.

### Eliminizer® Combo

*Description:* (2) stage assembly which combines an Eliminizer® (filter-dryer) with a high efficiency Coalescer to give superior oil & fine particulate capture, in addition to heavy water removal. 99.99998% efficient at 0.01 micron. ISO Class 1 Particulate/Oil.

*Port Size Range:* ¼" NPT to 1" NPT

*Flow Range:* 20 scfm to 150 scfm @ 100 PSI

*Applications:* Generally used at point of use and in heavy duty service where heavy water, dirt & oil removal is needed.

### Coalescer

*Description:* High efficiency coalescer, 99.99998% efficient at 0.01 micron, with anti-re-entrainment layer for low oil carryover. ISO Class 1 Particulate/Oil.

*Port Size Range:* ¼" NPT to 6" ASA (150#) Flange

*Flow Range:* 20 scfm to 3000 scfm @ 100 PSI

*Applications:* Generally used in mainlines or at point of use, where oil and/or fine particulate capture is required.

### Oil Extractor®

*Description:* RTi patented inverse flow filter-dryer with (4) stage filter packing, including an activated carbon packing backed by a cotton/polyester packing. Excellent water, dirt & oil aerosol capture to 1 micron. ISO Class 1 Particulate/Oil.

*Port Size Range:* ¼" NPT to 1" NPT

*Flow Range:* 60 scfm to 150 scfm @ 100 PSI

*Applications:* Generally used at point of use and in heavy duty service where heavy water, dirt & oil removal is needed. Can be used in combination with a coalescer (see below) to get a higher efficiency filtration (to 0.01 micron).

### Oil Extractor® Combo

*Description:* (2) stage assembly which combines an Oil Extractor® with a high efficiency Coalescer to give the best oil & fine particulate capture, in addition to heavy water removal. 99.99998% efficient at 0.01 micron and to 0.003 ppm. ISO Class 1 Particulate/Oil.

*Port Size Range:* ¼" NPT to 1" ASA (150#) Flange

*Flow Range:* 60 scfm to 150 scfm @ 100 PSI

*Applications:* Generally used at point of use where heavy water, dirt, oil & oil aerosol removal is needed.

# Choosing the Right Filter: By Contaminant

*Determine the right filter, and the page you can find it on in this guide – organized by contaminant/filtration capacity.*

	System	Filtration/ Dew Point	Contamination					Page
			Moisture		Particulate (Dirt)	Oil	Odor	
			Water	Dew Point Suppression				
Compressor Room /Mainline	<b>A</b> Eliminex	3.0 micron	•		•			1
	<b>B</b> Coalescer	0.01 micron			•	•		17
	<b>C</b> Eliminex Combo	0.01 micron	•		•	•		6
	<b>D</b> Refrigerated Dryer	38 °F		•				39
Point of Use Application	<b>E</b> Eliminator	1.0 micron	•		•			11
	<b>F</b> Coalescer	0.01 micron			•	•		17
	<b>G</b> Eliminator Combo	0.01 micron	•		•	•		14
	<b>H</b> Oil-Extractor Combo	0.01 micron	•		•	•	•	25
	<b>I</b> Desiccant Dryers	-40 °F		•				40
	<b>J</b> High Pressure Eliminator	1.0 micron	•		•			Consult Factory
	<b>K</b> High Pressure Coalescer	0.01 micron			•	•		38
	<b>L</b> High Pressure Eliminator Combo	0.01 micron	•		•	•		Consult Factory
	<b>M</b> Food Grade Eliminator	1.0 micron	•		•			29
	<b>N</b> Food Grade Coalescer	0.01 micron			•	•		32
	<b>O</b> Food Grade Oil-Extractor Combo	0.01 micron	•		•	•	•	31
	<b>P</b> Stainless Steel Eliminator	1.0 micron	•		•			33
	<b>Q</b> Stainless Steel Coalescer	0.01 micron			•	•		36
	<b>R</b> Stainless Steel Oil-Extractor Combo	0.01 micron	•		•	•	•	35



## The Compressed Air Quality Standard: ISO 8573.1

We follow air quality standards as defined by ISO — the International Standards Organization. These internationally recognized standards for air quality and product design categorize our products into different ISO Classes by contaminant type ( water, dirt, oil) & air quality levels.

Class	Solid Particulates (Dirt) (maximum number of particles per m <sup>3</sup> )			Water Pressure Dewpoint (°F)	Oil Solids & Vapor (mg/m <sup>3</sup> )
	0.1-0.5 micron	0.5-1.0 micron	1.0-5.0 micron		
1	100	1	0	-94.0	0.01
2	100,000	1,000	10	-40.0	0.1
3		10,000	500	-4.0	1.0
4			1,000	37.4	5.0

see Product Pages for ISO Classes

## Why should I care about the quality of my compressed air?

Clean, dry air is important—whatever the application may be. In air powered production systems, components are affected by contamination:



Device	Effects		
	Water (Moisture)	Particulate	Oil
<b>Piping</b>	rust & scale	component failure	component failure
<b>Air Cylinders</b>	reduced component life lubricant wash-out component failure	poor sealing of piston rod reduced service life	reduced component life
<b>Air Valves</b>	sticking spools coil failure lubricant wash-out	seal failure clogged mufflers	reduced component life swollen seals valve failure
<b>Pneumatic Positioners</b>	IP & EP failure valve failure positioning problems	clogged orifices equipment malfunction	seal failure
<b>Spraying Equipment</b>	poor curing loss of gloss poor color match	increased cutting & buffing	fish eyes poor quality finish
<b>Air Tools</b>	internal corrosion lubricant wash-out	internal wear seal failure	swollen seals
<b>Air Motors Air Bearings</b>	catastrophic failure reduced efficiency	clogged orifices reduced efficiency	inaccurate measurements instrumentation error
<b>Laser Cutters Plasma Cutters</b>	tip failure poor surface finish	clogged orifices	tip failure mirror coating

# Which system is right for you?

Compressed air systems can be designed to meet customer requirements. RTi can assist in your specification process to determine the most cost-effective, practical design for your individual applications. Be sure to view the corresponding page numbers for more information on these products.

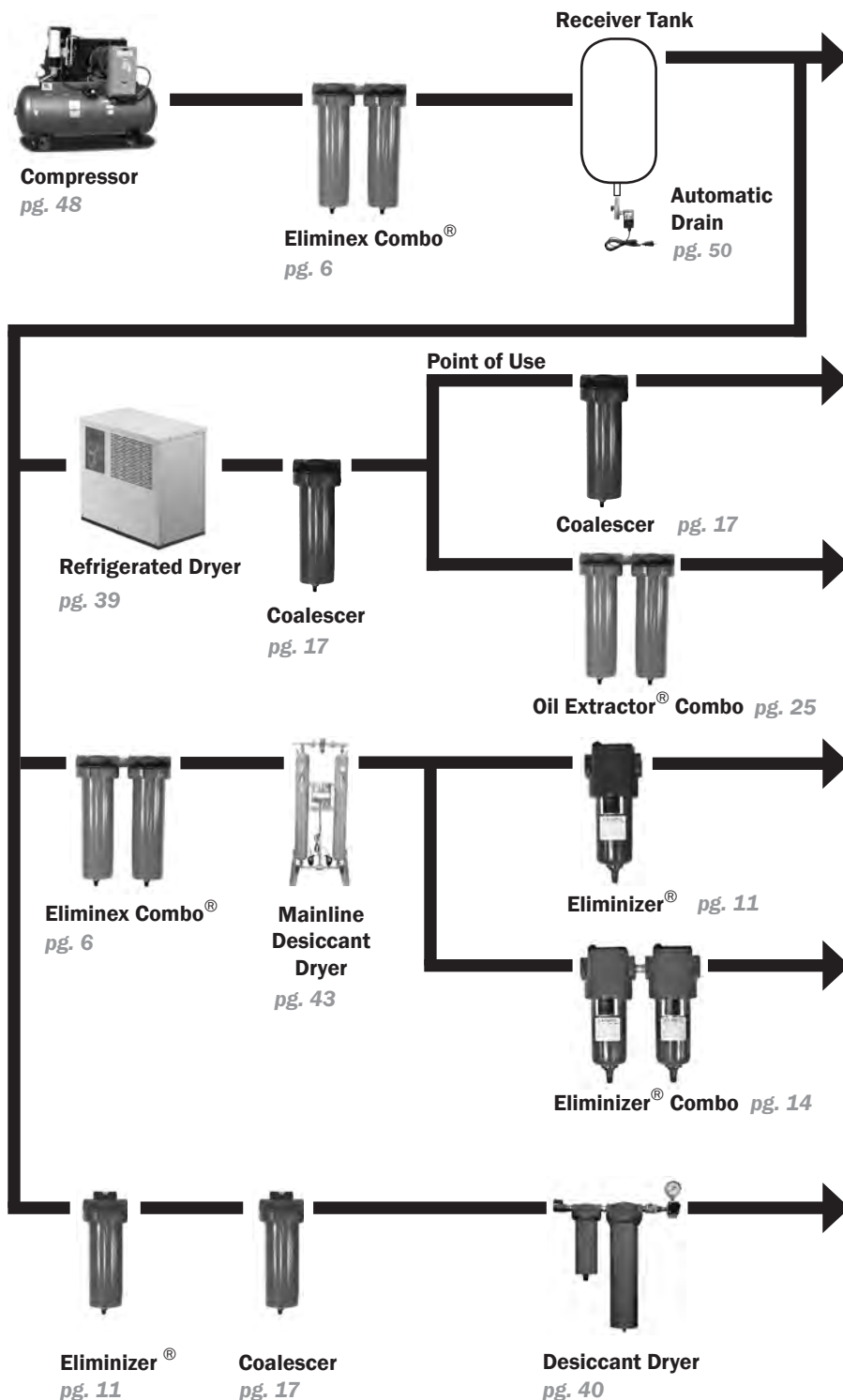

Pressure Dewpoint	Filtration Capacity		
	Solid Particles	Oil Aerosols	Oil Vapors
90°F to 110°F	0.01 micron & larger	99.9%+	N.R.*
38°F to 50°F	0.01 micron & larger	99.9%+	N.R.
38°F to 50°F	0.01 micron & larger	99.9%+	Filtered with Activated Carbon to 0.003 ppm
-40°F to -100°F	1.0 micron & larger	99.9%+	N.R.
-40°F to -100°F	0.01 micron & larger	99.9%+	to 0.01 ppm
40°F to -40°F	0.01 micron & larger	99.9%+	N.R.

\* N.R. Hydro Carbon Vapor Not Removed



# Guide: Understanding the Product Pages

**DE350-P02, DE350-P04, DE301-M04, DE401-M04**

Product Title

## Specifications

**Port Sizes** ¼" - ½"  
**Thread Styles** NPT  
**Flow Capacity** 25 scfm @ 100 PSI  
**Filter Capacity** 1.0 Micron & larger  
**Differential Pressure** <5.0 PSID at rated flow  
**Max Temp/ Pressure**  
**Aluminum Bowl** 175° F/200 PSIG  
**Max Temp/ Pressure**  
**Polycarbonate Bowl** 125° F/150 PSIG  
**Approx. Weight (lb.)** 8.0  
**ISO Class** 2 Particulate/Oil & Class 2 Pressure Dew Point



**Water**  
**Dirty**  
**Oil**  
**Oil Vapor**  
**Water Vapor**  
**Odor**

Items in **bold** indicate the filtration capacity of the unit.

## Replacement Parts & Accessories

Description	Part Number
<b>A</b> Replacement Element, 1st stage	DE301/DE350/DE401
<b>B</b> O-ring: for DE350-P02/P04 & DE301-M04	N32-95-256
<b>B</b> O-ring: for DE401-M04	N32-95-257
<b>C</b> Bowl Assy: for DE301-M04 (Bowl, Drain, O-ring)	N34-95-201
<b>C</b> Bowl Assy: for DE350-P02/P04 (Bowl, Drain, O-ring)*	N32-15-167
<b>C</b> Bowl Assy: for DE401-M04 (Bowl, Drain, O-ring)	N34-15-180
<b>D</b> Manual Brass Petcock Drain:for DE350-P02/P04	N32-95-182
<b>D</b> Petcock Drain: for DE301-M04	PC-02
<b>D</b> Petcock Drain: for DE401-M04	PC-03
Sight Glass Assy: for DE401-M04	RTI-SG-651

\*Poly bowls come with metal bowl guard

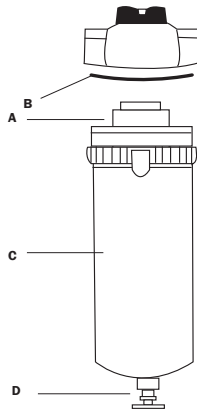

Replacement Parts & Accessories:  
 Letters on the part breakdown correspond to the adjacent chart for easy reference.

## Order Guide

	Port Size	Bowl Type	Flow Capacity	Dimensions (inches)		
				Height*	Width	Depth
DE350-P02	¼"	Poly	10scfm	13.6	5.2	4.8
DE350-P04	½"	Poly	10 scfm	13.6	4.6	4.8
DE301-M04	½"	Metal	8 scfm	9.9	3.9	3.9
DE401-M04	½"	Metal	10 scfm	16.5	6.8	4.8

\*To add an indicator, add "I" to end of part number (Indicator adds about 1" to height)

The Order Guide:  
 Choose the right model for your application--  
 Narrow down your choices by:  
 Port size, bowl material (metal/polycarbonate),  
 drain style, or flow capacity (scfm).  
 Dimensions also included.

Can't find the information you need on the page?

Call us for more information or visit our website for downloadable PDFs & literature on our products.

Don't ignore the fine print!  
 It lets you know about  
 additional models, parts,  
 optional items, and  
 recommended specifications  
 for certain products.

1 Year Warranty | (800) 521-9200





# Industrial Numbering System

Below is a guide to understanding the model numbers of our product lines found on the following pages.

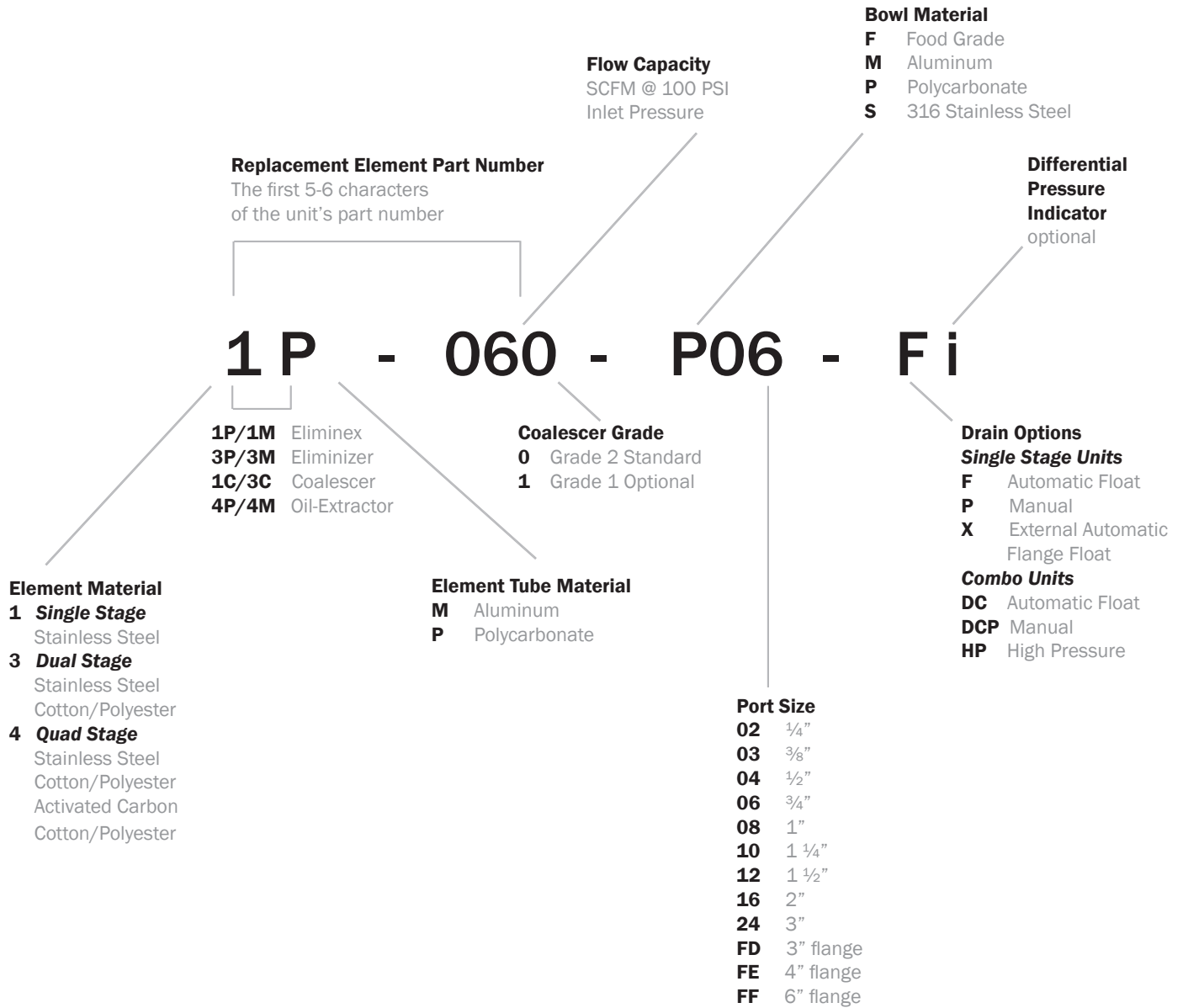

(800) 521-9200

PDF available at [www.driair.com](http://www.driair.com)

# Specifications

<b>Port Sizes</b>	1/4", 3/8", 1/2"
<b>Thread Styles</b>	NPT, BSPT, BSPP
<b>Flow Capacity</b>	60 scfm @ 100 PSI
<b>Filter Capacity</b>	3.0 Micron & larger
<b>Differential Pressure</b>	< 1.5 PSID at rated flow
<b>Max Temp/ Pressure</b>	
<b>Aluminum Bowl</b>	175 °F/200 PSIG
<b>Max Temp/ Pressure</b>	
<b>Polycarbonate Bowl</b>	125 °F/150 PSIG
<b>Approx. Weight (lb.)</b>	3.5
<b>ISO Class</b>	3 Particulate

For higher pressure applications, consult factory.  
Units equipped with differential pressure indicator have max temperature and pressure of 125 °F and 150 PSIG, regardless of bowl material.



**Water**  
**Dirt**  
**Oil**  
**Oil Vapor**  
**Odor**

# Replacement Parts & Accessories

Description	Part Number
<b>A</b> Replacement Element	1P-060
<b>B</b> Differential Pressure Indicator	N32-W1-DPI
<b>B</b> Blanking Cap (Cover for Indicator)	N32-95-020
<b>C</b> Bowl Assembly: Metal Bowl, Manual Petcock Drain, & O-ring	N34-95-205
<b>C</b> Bowl Assembly: Metal Bowl, Auto Float Drain, & O-ring	N34-95-201
<b>C</b> Bowl Assembly: Poly Bowl & Manual Petcock Drain*	N32-15-163
<b>C</b> Bowl Assembly: Poly Bowl & Auto Float Drain*	N32-15-164
<b>D</b> Manual Petcock Drain	PC-02/PC-03
<b>E</b> Automatic Float Drain (Metal Bowl)	N32-95-979
<b>E</b> Automatic Brass Float Drain (Poly Bowl)	N32-95-978
<b>F</b> Bowl O-ring	N32-95-257

\*Poly bowls come with metal bowl guard

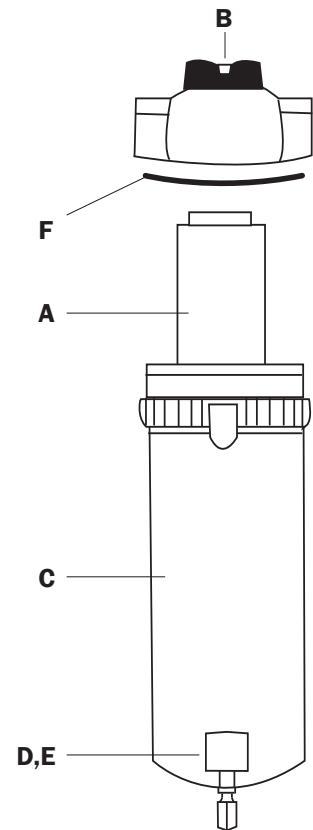

# Order Guide

	Port Size	Model Number	
		Metal Bowl	Poly Bowl
<b>Manual Brass Petcock Drain</b>	1/4"	1P-060-M02-P	1P-060-P02-P
	3/8"	1P-060-M03-P	1P-060-P03-P
	1/2"	1P-060-M04-P	1P-060-P04-P
<b>Automatic Float Drain</b>	1/4"	1P-060-M02-F	1P-060-P02-F
	3/8"	1P-060-M03-F	1P-060-P03-F
	1/2"	1P-060-M04-F	1P-060-P04-F

Dimensions (inches)			
Height*		Width	Depth
Metal	Poly		
10.0	10.0	3.9	3.9
10.0	10.0	3.9	3.9
10.0	10.0	3.9	3.9
10.0	10.5	3.9	3.9
10.0	10.5	3.9	3.9
10.0	10.5	3.9	3.9

\*To add an indicator, add "i" to end of model number (Indicator adds about 1" to height)

# Specifications

<b>Port Sizes</b>	½", ¾", 1"
<b>Thread Styles</b>	NPT, BSPT, BSPP
<b>Flow Capacity</b>	120/175/250 scfm @ 100 PSI
<b>Filter Capacity</b>	3.0 Micron & larger
<b>Differential Pressure</b>	< 1.5 PSID at rated flow
<b>Max Temp/ Pressure</b>	
<b>Aluminum Bowl</b>	175 °F/200 PSIG
<b>Max Temp/ Pressure</b>	
<b>Polycarbonate Bowl</b>	125 °F/150 PSIG
<b>Approx. Weight (lb.)</b>	6.0
<b>ISO Class</b>	3 Particulate

For higher pressure applications, consult factory. Units equipped with differential pressure indicator have max temperature and pressure of 125 °F and 150 PSIG, regardless of bowl material.



**Water**  
**Dirt**  
**Oil**  
**Oil Vapor**  
**Odor**

	Dimensions ( inches )			
	Height*		Width	Depth
	Metal	Poly		
Manual Brass Petcock Drain	17.0	14.0	4.6	4.8
Automatic Float Drain	17.0	14.5	4.6	4.8

# Replacement Parts & Accessories

Description	Part Number
<b>A</b> Replacement Element	1P-120/1P-175/1P-250
<b>B</b> Differential Pressure Indicator	N32-W1-DPI
<b>B</b> Blanking Cap (Cover for Indicator)	N32-95-020
<b>C</b> Bowl Assembly: Metal Bowl, Manual Petcock Drain, & O-ring	N34-15-180
<b>C</b> Bowl Assembly: Metal Bowl, Auto Float Drain & O-ring	N34-15-178
<b>C</b> Bowl Assembly: Poly Bowl, Manual Petcock Drain, & O-ring*	N32-15-167
<b>C</b> Bowl Assembly: Poly Bowl, Auto Float Drain & O-ring*	N32-15-166
<b>D</b> Manual Petcock Drain	PC-03
<b>E</b> Automatic Float Drain (Metal Bowl)	N32-95-979
<b>E</b> Automatic Brass Float Drain (Poly Bowl)	N32-95-978
<b>F</b> Bowl O-ring	N32-95-256

\*Poly bowls come with metal bowl guard

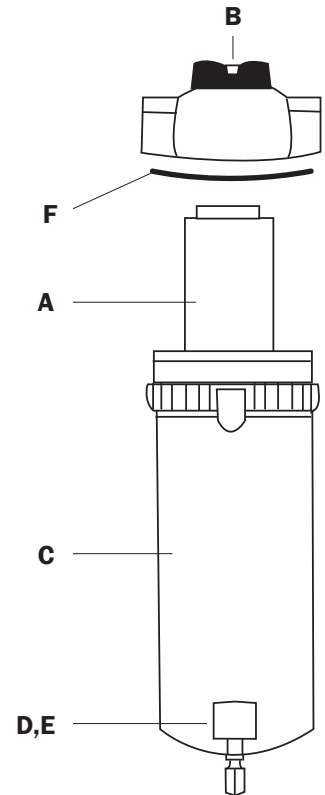

# Order Guide

	Port Size	Model Number					
		Metal Bowl			Poly Bowl		
		Low Flow	Med Flow	High Flow	Low Flow	Med Flow	High Flow
<b>Manual Brass Petcock Drain</b>	½"	1P-120-M04-P	1P-175-M04-P	1P-250-M04-P	1P-120-P04-P	1P-175-P04-P	1P-250-P04-P
	¾"	1P-120-M06-P	1P-175-M06-P	1P-250-M06-P	1P-120-P06-P	1P-175-P06-P	1P-250-P06-P
	1"	1P-120-M08-P	1P-175-M08-P	1P-250-M08-P	1P-120-P08-P	1P-175-P08-P	1P-250-P08-P
<b>Automatic Float Drain</b>	½"	1P-120-M04-F	1P-175-M04-F	1P-250-M04-F	1P-120-P04-F	1P-175-P04-F	1P-250-P04-F
	¾"	1P-120-M06-F	1P-175-M06-F	1P-250-M06-F	1P-120-P06-F	1P-175-P06-F	1P-250-P06-F
	1"	1P-120-M08-F	1P-175-M08-F	1P-250-M08-F	1P-120-P08-F	1P-175-P08-F	1P-250-P08-F

\*To add an indicator, add "i" to end of model number (Indicator adds about 1" to height)



(800) 521-9200

PDF available at [www.driair.com](http://www.driair.com)

# Specifications

<b>Port Sizes</b>	1¼", 1½", 2"
<b>Thread Styles</b>	NPT, BSPT, BSPP
<b>Flow Capacity</b>	300/400/700 scfm @ 100 PSI
<b>Filter Capacity</b>	3.0 Micron & larger
<b>Differential Pressure</b>	< 1.5 PSID at rated flow
<b>Max Temp/ Pressure</b>	
<b>Aluminum Bowl</b>	175 °F/200 PSIG
<b>Approx. Weight (lb.)</b>	30.0
<b>ISO Class</b>	3 Particulate

For higher pressure applications, consult factory.  
 Units equipped with differential pressure indicator have max temperature and pressure of 125 °F and 150 PSIG, regardless of bowl material.

**Water**  
**Dirt**  
 Oil  
 Oil Vapor  
 Odor

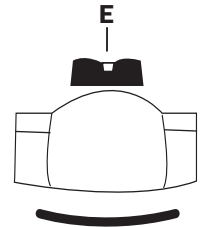

# Replacement Parts & Accessories

Description	Part Number
<b>A</b> Replacement Element	1M-300/1M-400/1M-700
<b>B</b> Manual Drain, Ball Valve	BV-051
<b>C</b> Automatic Float Drain	N32-95-XD8
<b>D</b> Bowl O-ring	N32-F35-OR
<b>E</b> Differential Pressure Indicator (Optional)	N32-W1-DPI

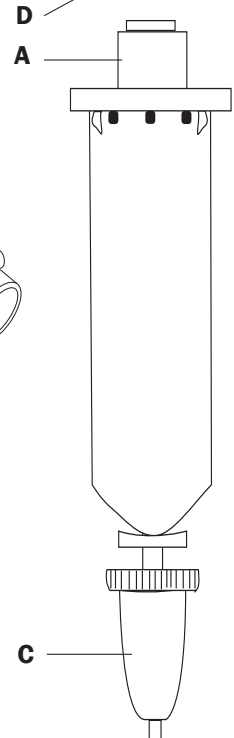
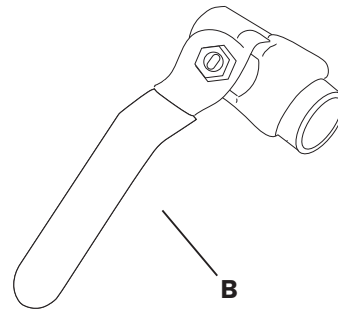

# Order Guide

	Port Size	Model Number		
		Low Flow	Med Flow	High Flow
<b>Manual Brass Petcock Drain</b>	1¼"	1M-300-M10-P	1M-400-M10-P	1M-700-M10-P
	1½"	1M-300-M12-P	1M-400-M12-P	1M-700-M12-P
	2"	1M-300-M16-P	1M-400-M16-P	1M-700-M16-P
<b>External Automatic Float Drain</b>	1¼"	1M-300-M10-F	1M-400-M10-F	1M-700-M10-F
	1½"	1M-300-M12-F	1M-400-M12-F	1M-700-M12-F
	2"	1M-300-M16-F	1M-400-M16-F	1M-700-M16-F

Dimensions (inches)		
Height*	Width	Depth
28.0	7.8	7.8
28.0	7.8	7.8
28.0	7.8	7.8
32.0	7.8	7.8
32.0	7.8	7.8
32.0	7.8	7.8

\*To add an indicator, add "i" to end of model number (Indicator adds about 1" to height)



# Specifications

<b>Port Sizes</b>	3"
<b>Thread Styles</b>	NPT
<b>Flow Capacity</b>	1200 scfm @ 100 PSI
<b>Filter Capacity</b>	3.0 Micron & larger
<b>Differential Pressure</b>	< 1.5 PSID at rated flow
<b>Max Temp/ Pressure</b>	
<b>Aluminum Bowl</b>	175 °F/200 PSIG (manual drain)
	175 °F/150 PSIG (float drain)
<b>Approx. Weight (lb.)</b>	38.0
<b>ISO Class</b>	3 Particulate

For higher pressure units, consult factory.

**Water**  
**Dirt**  
**Oil**  
**Oil Vapor**  
**Odor**



# Replacement Parts & Accessories

Description	Part Number
<b>A</b> Replacement Element	1M-1200
<b>B</b> Manual Drain, Ball Valve	BV-051
<b>C</b> Automatic Float Drain	N32-95-XD8
<b>D</b> Bowl O-ring	PHC-032

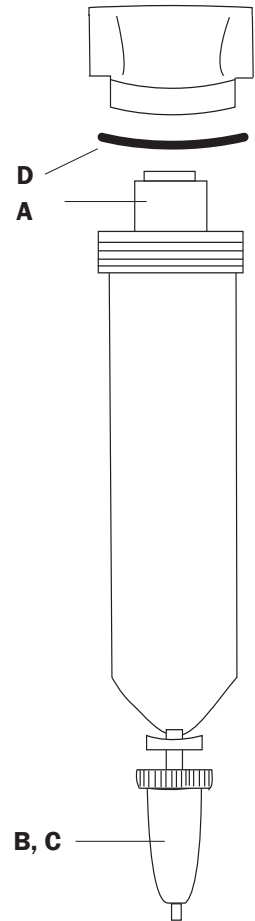

# Order Guide

	Port Size	Model Number	Dimensions (inches)		
			Height	Width	Depth
Manual Brass Petcock Drain	3"	1M-1200-M24-P	40.0	8.0	7.3
Automatic Float Drain	3"	1M-1200-M24-F	44.0	8.0	7.3



(800) 521-9200

PDF available at [www.driair.com](http://www.driair.com)

# Specifications

<b>Port Sizes</b>	3", 4", 6" RFSO
<b>Connection</b>	Raised face 150# Flange
<b>Flow Capacity</b>	2500/5500 scfm @ 100 PSI
<b>Filter Capacity</b>	3.0 Micron & larger
<b>Differential Pressure</b>	< 1.5 PSID at rated flow
<b>Max Temp/ Pressure</b>	
<b>Epoxy Coated Carbon Steel</b>	150 °F/200 PSIG
<b>Approx. Weight (lb.)</b>	300/310/450
<b>ISO Class</b>	3 Particulate

For higher pressure applications, consult factory.  
Units equipped with an external auto drain have max temperature and pressure of 150 °F and 150 PSIG.



**Water**  
**Dirt**  
**Oil**  
**Oil Vapor**  
**Odor**

# Replacement Parts & Accessories

Description	Part Number
<b>A</b> Differential Pressure Indicator	N32-P2-DPI
<b>B</b> External Float Drain	N32-95-XD8
Manual Drain, Ball Valve	BV-051
Replacement Element	1X-2500/1X-5500

Note:  
All 1M-2500 units require a minimum of 25" clearance between bottom of housing and floor for installation.  
All 1M-5500 units require a minimum of 36" clearance between bottom of housing and floor for installation.

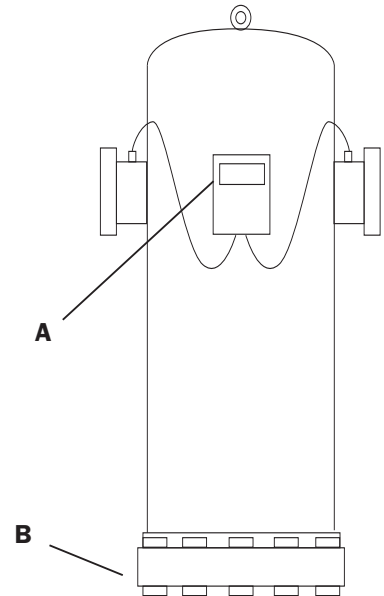

# Order Guide

	Port Size	Model Number (ASME Vessel)	Dimensions (inches)		
			Height	Width	Depth
<b>Manual Brass Petcock Drain</b>	3"	1M-2500-MFD-P	50.2	20.0	16.0
	4"	1M-2500-MFE-P	50.2	20.0	16.0
	6"	1M-5500-MFF-P	68.0	23.4	19.0
<b>Automatic Float Drain</b>	3"	1M-2500-MFD-X	54.2	20.0	16.0
	4"	1M-2500-MFE-X	54.2	20.0	16.0
	6"	1M-5500-MFF-X	72.0	23.4	19.0

Indicator is included as standard with these powder coated steel units.

# Specifications

<b>Port Sizes</b>	1/4", 3/8", 1/2"
<b>Thread Styles</b>	NPT, BSPT, BSPP
<b>Flow Capacity</b>	60 scfm @ 100 PSI
<b>Filter Capacity</b>	0.01 Micron & larger
<b>Differential Pressure</b>	< 2.5 PSID at rated flow
<b>Max Temp/ Pressure</b>	
<b>Aluminum Bowl</b>	175°F/200 PSIG
<b>Max Temp/ Pressure</b>	
<b>Polycarbonate Bowl</b>	125°F/150 PSIG
<b>Approx. Weight (lb.)</b>	7.0
<b>ISO Class</b>	1 Particulate/Oil

For higher pressure applications, consult factory.  
 Units equipped with differential pressure indicator  
 have max temperature and pressure of 125°F and  
 150 PSIG, regardless of bowl material.



**Water**  
**Dirt**  
**Oil**  
**Oil Vapor**  
**Odor**

# Replacement Parts & Accessories

Description	Part Number
<b>A</b> Replacement Element, 1st Stage	1P-060
<b>B</b> Replacement Element, 2nd Stage	3C-060
<b>C</b> Differential Pressure Indicator	N32-W1-DPI
<b>C</b> Blanking Cap (Cover for Indicator)	N32-95-020
<b>D</b> Bowl Assembly: Metal Bowl, Manual Petcock Drain, & O-ring	N34-95-205
<b>D</b> Bowl Assembly: Metal Bowl, Auto Float Drain, & O-ring	N34-95-201
<b>D</b> Bowl Assembly: Poly Bowl, Manual Petcock Drain, & O-ring*	N32-15-163
<b>D</b> Bowl Assembly: Poly Bowl, Auto Float Drain, & O-ring*	N32-15-164
<b>E</b> Manual Petcock Drain	PC-02
<b>F</b> Automatic Float Drain (Metal Bowl)	N32-95-979
<b>F</b> Automatic Brass Float Drain	N32-95-978
<b>G</b> Bowl O-ring	N32-95-257

\*Poly bowls come with metal bowl guard

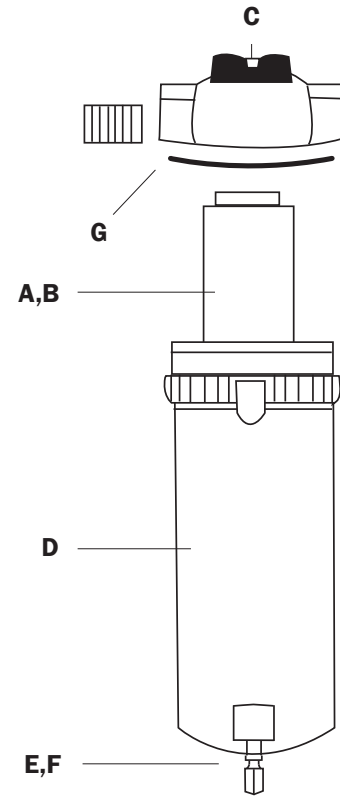

# Order Guide

	Port Size	Model Number	
		Metal Bowl	Poly Bowl
<b>Manual Brass Petcock Drain</b>	1/4"	1P-060-M02-DCP	1P-060-P02-DCP
	3/8"	1P-060-M03-DCP	1P-060-P03-DCP
	1/2"	1P-060-M04-DCP	1P-060-P04-DCP
<b>Automatic Float Drain</b>	1/4"	1P-060-M02-DC	1P-060-P02-DC
	3/8"	1P-060-M03-DC	1P-060-P03-DC
	1/2"	1P-060-M04-DC	1P-060-P04-DC

Dimensions (inches)			
Height*		Width	Depth
Metal	Poly		
10.0	10.0	8.0	3.9
10.0	10.0	8.0	3.9
10.0	10.0	8.0	3.9
10.0	10.5	8.0	3.9
10.0	10.5	8.0	3.9
10.0	10.5	8.0	3.9

\*To add an indicator, add "i" to end of model number (Indicator adds about 1" to height)



(800) 521-9200

PDF available at [www.driair.com](http://www.driair.com)

# Specifications

<b>Port Sizes</b>	1/2", 3/4", 1"
<b>Thread Styles</b>	NPT, BSPT, BSPP
<b>Flow Capacity</b>	90/150/250 scfm @ 100 PSI
<b>Filter Capacity</b>	0.01 Micron & larger
<b>Differential Pressure</b>	< 2.5 PSID at rated flow
<b>Max Temp/ Pressure</b>	
<b>Aluminum Bowl</b>	175 °F/200 PSIG
<b>Max Temp/ Pressure</b>	
<b>Polycarbonate Bowl</b>	125 °F/150 PSIG
<b>Approx. Weight (lb.)</b>	12.0
<b>ISO Class</b>	1 Particulate/Oil

For higher pressure applications, consult factory.  
Units equipped with differential pressure indicator have max temperature and pressure of 125 °F and 150 PSIG, regardless of bowl material.



**Water**  
**Dirt**  
**Oil**  
**Oil Vapor**  
**Odor**

	Dimensions (inches)			
	Height*		Width	Depth
	Metal	Poly		
<b>Manual Drain</b>	17.0	14.0	10.0	4.6
<b>Auto Float Drain</b>	17.0	14.5	10.0	4.6

# Replacement Parts & Accessories

Description	Part Number
<b>A</b> Replacement Element, 1st Stage	1P-090/1P-150/1P-250
<b>B</b> Replacement Element, 2nd Stage	3C-090/3C-150/3C-250
<b>C</b> Differential Pressure Indicator	N32-W1-DPI
<b>C</b> Blanking Cap (Cover for Indicator)	N32-95-020
<b>D</b> Bowl Assembly: Metal Bowl, Manual Petcock Drain, & O-ring	N34-15-180
<b>D</b> Bowl Assembly: Metal Bowl, Auto Float Drain, & O-ring	N34-15-178
<b>D</b> Bowl Assembly: Poly Bowl, Manual Petcock Drain, & O-ring*	N32-15-167
<b>D</b> Bowl Assembly: Poly Bowl, Auto Float Drain, & O-ring*	N32-15-166
<b>E</b> Manual Petcock Drain (Metal Bowl)	PC-03
<b>E</b> Manual Petcock Drain (Poly Bowl)	N32-95-182
<b>F</b> Automatic Plastic Float Drain (Metal Bowl)	N32-95-979
<b>F</b> Automatic Brass Float Drain	N32-95-978
<b>G</b> Bowl O-ring	N32-95-256

\*Poly bowls come with metal bowl guard

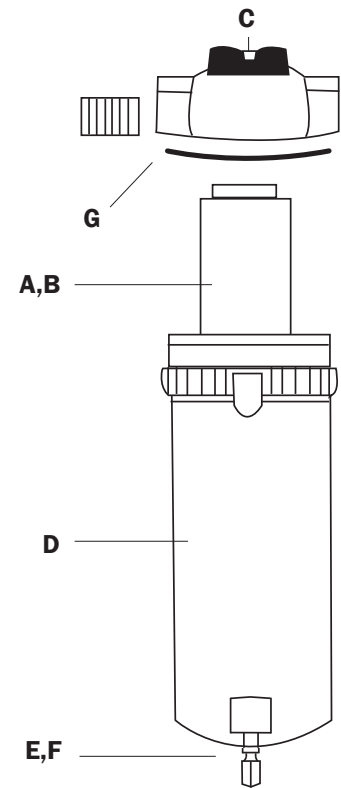

# Order Guide

	Port Size	Model Number					
		Metal Bowl			Poly Bowl		
		Low Flow	Med Flow	High Flow	Low Flow	Med Flow	High Flow
<b>Manual Brass Petcock Drain</b>	1/2"	1P-090-M04-DCP	1P-150-M04-DCP	1P-250-M04-DCP	1P-090-P04-DCP	1P-150-P04-DCP	1P-250-P04-DCP
	3/4"	1P-090-M06-DCP	1P-150-M06-DCP	1P-250-M06-DCP	1P-090-P06-DCP	1P-150-P06-DCP	1P-250-P06-DCP
	1"	1P-090-M08-DCP	1P-150-M08-DCP	1P-250-M08-DCP	1P-090-P08-DCP	1P-150-P08-DCP	1P-250-P08-DCP
<b>Automatic Float Drain</b>	1/2"	1P-090-M04-DC	1P-150-M04-DC	1P-250-M04-DC	1P-090-P04-DC	1P-150-P04-DC	1P-250-P04-DC
	3/4"	1P-090-M06-DC	1P-150-M06-DC	1P-250-M06-DC	1P-090-P06-DC	1P-150-P06-DC	1P-250-P06-DC
	1"	1P-090-M08-DC	1P-150-M08-DC	1P-250-M08-DC	1P-090-P08-DC	1P-150-P08-DC	1P-250-P08-DC

\*To add an indicator, add "i" to end of model number ( Indicator adds about 1" to height)





# Specifications

<b>Port Sizes</b>	1¼", 1½", 2"
<b>Thread Styles</b>	NPT, BSPT, BSPP
<b>Flow Capacity</b>	300/400/ 700 scfm @ 100 PSI
<b>Filter Capacity</b>	0.01 Micron & larger
<b>Differential Pressure</b>	< 2.5 PSID at rated flow
<b>Max Temp/ Pressure</b>	
<b>Aluminum Bowl</b>	175 °F/200 PSIG
<b>Approx. Weight (lb.)</b>	58.0/60.0/64.0
<b>ISO Class</b>	1 Particulate/Oil

For higher pressure applications, consult factory.  
 Units equipped with differential pressure indicator have max temperature and pressure of 125 °F and 150 PSIG, regardless of bowl material.



**Water**  
**Dirt**  
**Oil**  
**Oil Vapor**  
**Odor**

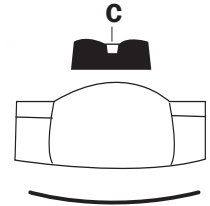

# Replacement Parts & Accessories

Description	Part Number
<b>A</b> Replacement Element, 1st Stage	1M-300/1M-400/1M-700
<b>B</b> Replacement Element, 2nd Stage	3C-300/3C-400/ 3C-700
<b>C</b> Differential Pressure Indicator	N32-W1-DPI
<b>C</b> Blanking Cap (Cover for Indicator)	N32-95-020
<b>D</b> Manual Drain, Ball Valve	BV-051
<b>E</b> Automatic Float Drain	N32-95-XD8
<b>F</b> Bowl O-ring	N32-F35-OR

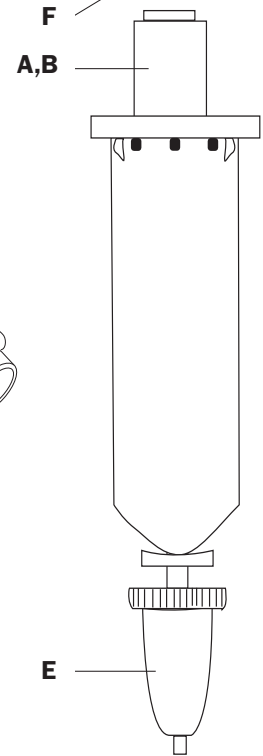
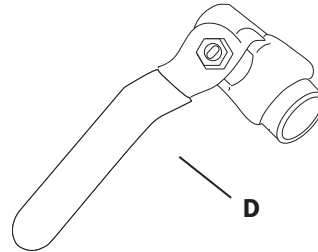

# Order Guide

	Port Size	Model Number		
		Low Flow	Med Flow	High Flow
Manual Brass Petcock Drain	1¼"	1M-300-M10-DCP	1M-400-M10-DCP	1M-700-M10-DCP
	1½"	1M-300-M12-DCP	1M-400-M12-DCP	1M-700-M12-DCP
	2"	1M-300-M16-DCP	1M-400-M16-DCP	1M-700-M16-DCP

Dimensions (inches)		
Height*	Width	Depth
28.0	16.5	7.8
28.0	16.8	7.8
28.0	17.0	7.8

Automatic Float Drain	1¼"	1M-300-M10-DC	1M-400-M10-DC	1M-700-M10-DC
	1½"	1M-300-M12-DC	1M-400-M12-DC	1M-700-M12-DC
	2"	1M-300-M16-DC	1M-400-M16-DC	1M-700-M16-DC

32.0	16.5	7.8
32.0	16.8	7.8
32.0	17.0	7.8

\*To add an indicator, add "i" to end of model number (Indicator adds about 1" to height)



(800) 521-9200

PDF available at [www.driair.com](http://www.driair.com)

# Specifications

<b>Port Sizes</b>	3"
<b>Thread Styles</b>	NPT
<b>Flow Capacity</b>	1200 scfm @ 100 PSI
<b>Filter Capacity</b>	0.01 Micron & larger
<b>Differential Pressure</b>	< 2.5 PSID at rated flow
<b>Max Temp/ Pressure</b>	175° F/200 PSIG (manual drain)
<b>Aluminum Bowl</b>	175° F/150 PSIG (float drain)
<b>Approx. Weight (lb.)</b>	76.0
<b>ISO Class</b>	1 Particulate/Oil

For higher pressure units, consult factory.



**Water**  
**Dirt**  
**Oil**  
**Oil Vapor**  
**Odor**

# Replacement Parts & Accessories

Description	Part Number
<b>A</b> Replacement Element	1M-1200
<b>B</b> Replacement Element, 2nd Stage	3C-1200
<b>C</b> Manual Drain, Ball Valve	BV-051
<b>D</b> Automatic Float Drain	N32-95-XD8
<b>E</b> Bowl O-ring	PHC-032

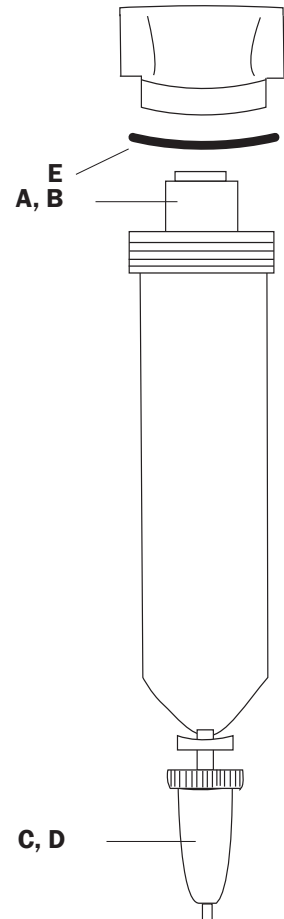

# Order Guide

	Port Size	Model Number	Dimensions (inches)		
			Height	Width	Depth
Manual Brass Petcock Drain	3"	1M-1200-M24-DCP	40.0	17.0	7.3
Automatic Float Drain	3"	1M-1200-M24-DC	44.0	17.0	7.3

# Specifications

<b>Port Sizes</b>	3", 4", 6" RFSO
<b>Connection</b>	Raised face 150# Flange
<b>Flow Capacity</b>	1900/3000 scfm @ 100 PSI
<b>Filter Capacity</b>	0.01 Micron & larger
<b>Differential Pressure</b>	< 2.5 PSID at rated flow
<b>Max Temp/ Pressure</b>	
<b>Epoxy Coated Carbon Steel</b>	150° F/200 PSIG
<b>Approx. Weight (lb.)</b>	600/620/900
<b>ISO Class</b>	1 Particulate/Oil

For higher pressure applications, consult factory.  
Units equipped with external auto drain have max temperature and pressure of 150° F and 150 PSIG.



**Water**  
**Dirt**  
**Oil**  
**Oil Vapor**  
**Odor**

# Replacement Parts & Accessories

Description	Part Number
<b>A</b> Replacement Element	1X-2500/1X-5500
<b>B</b> Replacement Element	3C-1900/3C-3000
<b>C</b> Differential Pressure Indicator	N32-P2-DPi
<b>D</b> Manual Drain, Ball Valve	BV-051
<b>E</b> External Float Drain	N32-95-XD8

Note:  
All 1900 scfm units require a minimum of 25" clearance between bottom of housing and floor for installation.  
All 3000 scfm units require a minimum of 36" clearance between bottom of housing and floor for installation.

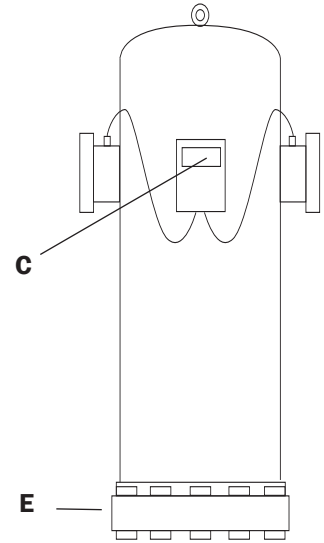

# Order Guide

	Port Size	Model Number
<b>Manual Brass Petcock Drain</b>	3"	1M-1900-MFD-DCP
	4"	1M-1900-MFE-DCP
	6"	1M-3000-MFF-DCP

Dimensions (inches)		
Height	Width	Depth
50.2	40.1	16.0
50.2	40.1	16.0
68.0	46.9	19.0

	Port Size	Model Number
<b>Automatic Float Drain</b>	3"	1M-1900-MFD-DCX
	4"	1M-1900-MFE-DCX
	6"	1M-3000-MFF-DCX

54.2	40.1	16.0
54.2	40.1	16.0
72.0	46.9	19.0

Indicator included as standard with metal bowl units.



# Specifications

<b>Port Sizes</b>	1/4", 3/8"
<b>Thread Styles</b>	NPT, BSPT, BSPP
<b>Flow Capacity</b>	20 scfm @ 100 PSI
<b>Filter Capacity</b>	1.0 Micron & larger
<b>Differential Pressure</b>	< 5.0 PSID at rated flow
<b>Max Temp/ Pressure</b>	
<b>Aluminum Bowl</b>	175 °F/200 PSIG
<b>Max Temp/ Pressure</b>	
<b>Polycarbonate Bowl</b>	125 °F/150 PSIG
<b>Approx. Weight (lb.)</b>	2.0
<b>ISO Class</b>	Class 2 Particulate

For higher pressure applications, consult factory.  
Units equipped with differential pressure indicator have max temperature and pressure of 125 °F and 150 PSIG, regardless of bowl material.



**Water**  
**Dirt**  
**Oil**  
**Oil Vapor**  
**Odor**

# Replacement Parts & Accessories

Description	Part Number
<b>A</b> Replacement Element	3P-020
<b>B</b> Differential Pressure Indicator	N32-W1-DPI
<b>B</b> Blanking Cap (Cover for Indicator)	N32-95-020
<b>C</b> Bowl Assembly: Metal Bowl, Manual Petcock Drain, & O-ring	N32-95-178
<b>C</b> Bowl Assembly: Metal Bowl, Auto Float Drain, & O-ring	N32-95-950
<b>D</b> Bowl Assembly: Poly Bowl, Manual Petcock Drain, & O-ring*	N32-15-159
<b>D</b> Bowl Assembly: Poly Bowl, Auto Float Drain, & O-ring*	N32-15-160
<b>E</b> Manual Petcock Drain	N32-95-182
<b>F</b> Automatic Plastic Float Drain	N32-95-973
<b>G</b> Bowl O-ring	N32-95-009

\*Poly bowls come with metal bowl guard

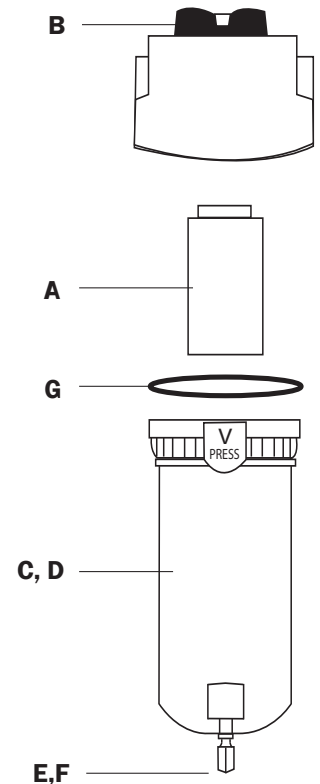

# Order Guide

	Port Size	Model Number		Dimensions (inches)		
		Metal Bowl	Poly Bowl	Height*	Width	Depth
<b>Manual Brass Petcock Drain</b>	1/4"	3P-020-M02-P	3P-020-P02-P	6.8	3.0	2.7
	3/8"	3P-020-M03-P	3P-020-P03-P	6.8	3.0	2.7
<b>Automatic Float Drain</b>	1/4"	3P-020-M02-F	3P-020-P02-F	6.8	3.0	2.7
	3/8"	3P-020-M03-F	3P-020-P03-F	6.8	3.0	2.7

\*To add an indicator, add "i" to end of model number (Indicator adds about 1" to height)

# Specifications

<b>Port Sizes</b>	¼", ⅜", ½"
<b>Thread Styles</b>	NPT, BSPT, BSPP
<b>Flow Capacity</b>	35 / 60 scfm @ 100 PSI
<b>Filter Capacity</b>	1.0 Micron & larger
<b>Differential Pressure</b>	< 5.0 PSID at rated flow
<b>Max Temp/ Pressure</b>	
<b>Aluminum Bowl</b>	175 °F/200 PSIG
<b>Max Temp/ Pressure</b>	
<b>Polycarbonate Bowl</b>	125 °F/150 PSIG
<b>Approx. Weight (lb.)</b>	3.5
<b>ISO Class</b>	2 Particulate

For higher pressure applications, consult factory.  
 Units equipped with differential pressure indicator have max temperature and pressure of 125 °F and 150 PSIG, regardless of bowl material.



**Water**  
**Dirt**  
**Oil**  
**Oil Vapor**  
**Odor**

# Replacement Parts & Accessories

	Description	Part Number
<b>A</b>	Replacement Element	3P-035/3P-060
<b>B</b>	Differential Pressure Indicator	N32-W1-DPI
<b>B</b>	Blanking Cap (Cover for Indicator)	N32-95-020
<b>C</b>	Bowl Assembly: Metal Bowl, Manual Petcock Drain, & O-ring	N34-95-205
<b>C</b>	Bowl Assembly: Metal Bowl, Auto Float Drain, & O-ring	N34-95-201
<b>D</b>	Bowl Assembly: Poly Bowl, Manual Petcock Drain, & O-ring*	N32-15-163
<b>D</b>	Bowl Assembly: Poly Bowl, Auto Float Drain, & O-ring*	N32-15-164
<b>E</b>	Manual Petcock Drain (Metal Bowl)	PC-02
<b>E</b>	Manual Petcock Drain (Poly Bowl)	N32-95-182
<b>F</b>	Automatic Plastic Float Drain (Metal Bowl)	N32-95-979
<b>F</b>	Automatic Brass Float Drain (Poly Bowl)	N32-95-978
<b>G</b>	Bowl O-ring	N32-95-257

\*Poly bowls come with metal bowl guard

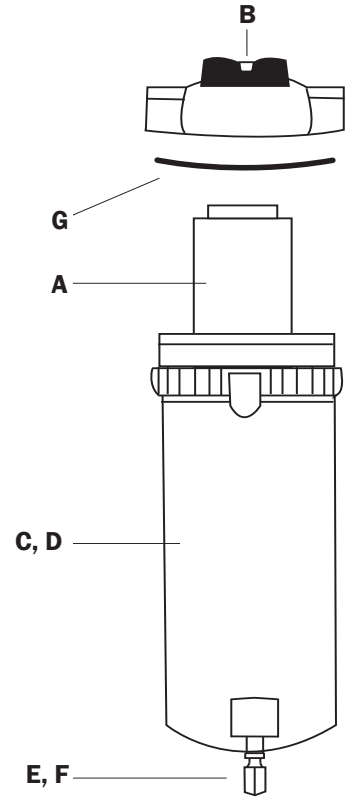

# Order Guide

	Port Size	Model Number				Dimensions (inches)			
		Metal Bowl		Poly Bowl		Height*		Width	Depth
		Low Flow	Med Flow	Low Flow	Med Flow	Metal	Poly		
<b>Manual Brass Petcock Drain</b>	¼"	3P-035-M02-P	3P-060-M02-P	3P-035-P02-P	3P-060-P02-P	10.0	10.0	3.9	3.9
	⅜"	3P-035-M03-P	3P-060-M03-P	3P-035-P03-P	3P-060-P03-P	10.0	10.0	3.9	3.9
	½"	3P-035-M04-P	3P-060-M04-P	3P-035-P04-P	3P-060-P04-P	10.0	10.0	3.9	3.9
<b>Automatic Float Drain</b>	¼"	3P-035-M02-F	3P-060-M02-F	3P-035-P02-F	3P-060-P02-F	10.0	10.5	3.9	3.9
	⅜"	3P-035-M03-F	3P-060-M03-F	3P-035-P03-F	3P-060-P03-F	10.0	10.5	3.9	3.9
	½"	3P-035-M04-F	3P-060-M04-F	3P-035-P04-F	3P-060-P04-F	10.0	10.5	3.9	3.9

\*To add an indicator, add "I" to end of model number (Indicator adds about 1" to height)



(800) 521-9200

PDF available at [www.driair.com](http://www.driair.com)

# Specifications

<b>Port Sizes</b>	½", ¾", 1"
<b>Thread Styles</b>	NPT, BSPT, BSPP
<b>Flow Capacity</b>	90/ 150 scfm @ 100 PSI
<b>Filter Capacity</b>	1.0 Micron & larger
<b>Differential Pressure</b>	< 5.0 PSID at rated flow
<b>Max Temp/ Pressure</b>	
<b>Aluminum Bowl</b>	175°F/200 PSIG
<b>Max Temp/ Pressure</b>	
<b>Polycarbonate Bowl</b>	125°F/150 PSIG
<b>Approx. Weight (lb.)</b>	6.0
<b>ISO Class</b>	2 Particulate

For higher pressure applications, consult factory.  
Units equipped with differential pressure indicator have max temperature and pressure of 125°F and 150 PSIG, regardless of bowl material.



**Water**  
**Dirt**  
**Oil**  
**Oil Vapor**  
**Odor**

# Replacement Parts & Accessories

Description	Part Number
<b>A</b> Replacement Element	3P-090/3P-150
<b>B</b> Differential Pressure Indicator	N32-W1-DPI
<b>B</b> Blanking Cap (Cover for Indicator)	N32-95-020
<b>C</b> Bowl Assembly: Metal Bowl, Manual Petcock Drain, & O-ring	N34-15-180
<b>C</b> Bowl Assembly: Metal Bowl, Auto Float Drain & O-ring	N34-15-178
<b>D</b> Bowl Assembly: Poly Bowl, Manual Petcock Drain, & O-ring*	N32-15-167
<b>D</b> Bowl Assembly: Poly Bowl, Auto Float Drain, & O-ring*	N32-15-166
<b>E</b> Manual Petcock Drain (Metal Bowl)	PC-03
<b>E</b> Manual Petcock Drain (Poly Bowl)	N32-95-182
<b>F</b> Automatic Plastic Float Drain (Metal Bowl)	N32-95-979
<b>F</b> Automatic Brass Float Drain (Poly Bowl)	N32-95-978
<b>G</b> Bowl O-ring	N32-95-256

\*Poly bowls come with metal bowl guard

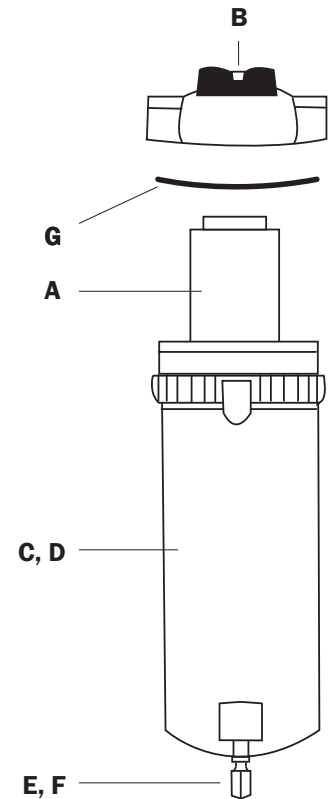

# Order Guide

	Port Size	Model Number			
		Metal Bowl		Poly Bowl	
		Low Flow	Med Flow	Low Flow	Med Flow
<b>Manual Brass Petcock Drain</b>	½"	3P-090-M04-P	3P-150-M04-P	3P-090-P04-P	3P-150-P04-P
	¾"	3P-090-M06-P	3P-150-M06-P	3P-090-P06-P	3P-150-P06-P
	1"	3P-090-M08-P	3P-150-M08-P	3P-090-P08-P	3P-150-P08-P
<b>Automatic Float Drain</b>	½"	3P-090-M04-F	3P-150-M04-F	3P-090-P04-F	3P-150-P04-F
	¾"	3P-090-M06-F	3P-150-M06-F	3P-090-P06-F	3P-150-P06-F
	1"	3P-090-M08-F	3P-150-M08-F	3P-090-P08-F	3P-150-P08-F

Dimensions (inches)			
Height*		Width	Depth
Metal	Poly		
17.0	14.0	4.6	4.8
17.0	14.0	4.6	4.8
17.0	14.0	4.6	4.8
17.0	14.5	4.6	4.8
17.0	14.5	4.6	4.8
17.0	14.5	4.6	4.8

\*To add an indicator, add "i" to end of model number (Indicator adds about 1" to height)



# Specifications

<b>Port Sizes</b>	1/4", 3/8"
<b>Thread Styles</b>	NPT, BSPT, BSPP
<b>Flow Capacity</b>	20 scfm @ 100 PSI
<b>Filter Capacity</b>	0.01 Micron & larger
<b>Differential Pressure</b>	< 5.0 PSID at rated flow
<b>Max Temp/ Pressure</b>	
<b>Aluminum Bowl</b>	175 °F/200 PSIG
<b>Max Temp/ Pressure</b>	
<b>Polycarbonate Bowl</b>	125 °F/150 PSIG
<b>Approx. Weight (lb.)</b>	4.0
<b>ISO Class</b>	1 Particulate/Oil

For higher pressure applications, consult factory.  
Units equipped with differential pressure indicator have max temperature and pressure of 125 °F and 150 PSIG, regardless of bowl material.



**Water**  
**Dirt**  
**Oil**  
*Oil Vapor*  
*Odor*

# Replacement Parts & Accessories

Description	Part Number
<b>A</b> Replacement Element, 1st Stage	3P-020
<b>B</b> Replacement Element, 2nd Stage	3C-020
<b>C</b> Differential Pressure Indicator	N32-W1-DPI
<b>C</b> Blanking Cap (Cover for Indicator)	N32-95-020
<b>D</b> Bowl Assembly: Metal Bowl, Manual Petcock Drain, & O-ring	N32-95-178
<b>D</b> Bowl Assembly: Metal Bowl, Auto Float Drain, & O-ring	N32-95-950
<b>E</b> Bowl Assembly: Poly Bowl, Manual Petcock Drain, & O-ring*	N32-15-159
<b>E</b> Bowl Assembly: Poly Bowl, Auto Float Drain, & O-ring*	N32-15-160
<b>F</b> Manual Petcock Drain	N32-95-182
<b>G</b> Automatic Plastic Float Drain (Metal Bowl)	N32-95-973
<b>G</b> Automatic Brass Float Drain (Poly Bowl)	N32-95-978
<b>H</b> Bowl O-ring	N32-95-009

\*Poly bowls come with metal bowl guard

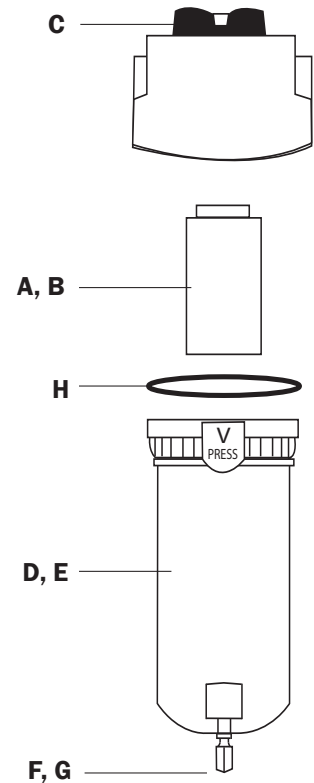

# Order Guide

	Port Size	Model Number	
		Metal Bowl	Poly Bowl
<b>Manual Brass Petcock Drain</b>	1/4"	3P-020-M02-DCP	3P-020-P02-DCP
	3/8"	3P-020-M03-DCP	3P-020-P03-DCP
<b>Automatic Float Drain</b>	1/4"	3P-020-M02-DC	3P-020-P02-DC
	3/8"	3P-020-M03-DC	3P-020-P03-DC

Dimensions (inches)		
Height*	Width	Depth
6.8	6.5	2.7
6.8	6.5	2.7
6.8	6.5	2.7
6.8	6.5	2.7

\*To add an indicator, add "i" to end of model number (Indicator adds about 1" to height)



(800) 521-9200

PDF available at [www.driair.com](http://www.driair.com)

# Specifications

<b>Port Sizes</b>	1/4", 3/8", 1/2"
<b>Thread Styles</b>	NPT, BSPT, BSPP
<b>Flow Capacity</b>	60 scfm @ 100 PSI
<b>Filter Capacity</b>	0.01 Micron & larger
<b>Differential Pressure</b>	< 5.0 PSID at rated flow
<b>Max Temp/ Pressure</b>	
<b>Aluminum Bowl</b>	175 °F/200 PSIG
<b>Max Temp/ Pressure</b>	
<b>Polycarbonate Bowl</b>	125 °F/150 PSIG
<b>Approx. Weight (lb.)</b>	7.0
<b>ISO Class</b>	1 Particulate/Oil

For higher pressure applications, consult factory.  
Units equipped with differential pressure indicator have max temperature and pressure of 125 °F and 150 PSIG, regardless of bowl material.



**Water**  
**Dirt**  
**Oil**  
**Oil Vapor**  
**Odor**

# Replacement Parts & Accessories

Description	Part Number
<b>A</b> Replacement Element, 1st Stage	3P-060
<b>B</b> Replacement Element, 2nd Stage	3C-060
<b>C</b> Differential Pressure Indicator	N32-W1-DPI
<b>C</b> Blanking Cap (Cover for Indicator)	N32-95-020
<b>D</b> Bowl Assembly: Metal Bowl, Manual Petcock Drain, & O-ring	N34-95-205
<b>D</b> Bowl Assembly: Metal Bowl, Auto Float Drain, & O-ring	N34-95-201
<b>E</b> Bowl Assembly: Poly Bowl, Manual Petcock Drain, & O-ring*	N32-15-163
<b>E</b> Bowl Assembly: Poly Bowl, Auto Float Drain, & O-ring*	N32-15-164
<b>F</b> Manual Petcock Drain (Metal Bowl)	PC-02
<b>F</b> Manual Petcock Drain (Poly Bowl)	N32-95-182
<b>G</b> Automatic Plastic Float Drain (Metal Bowl)	N32-95-979
<b>G</b> Automatic Brass Float Drain (Poly Bowl)	N32-95-978
<b>H</b> Bowl O-ring	N32-95-257

\*Poly bowls come with metal bowl guard

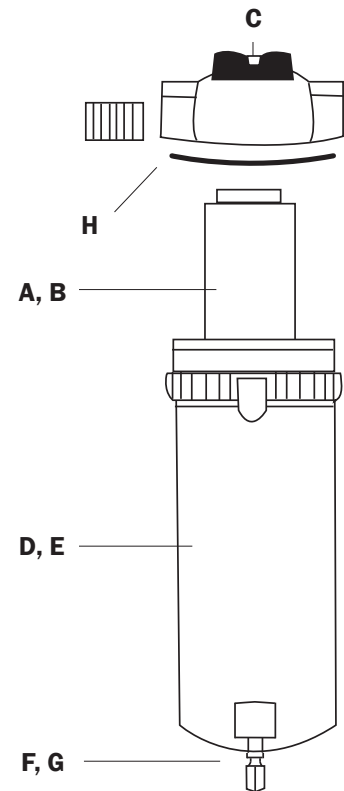

# Order Guide

	Port Size	Model Number		Dimensions (inches)			
		Metal Bowl	Poly Bowl	Height*		Width	Depth
				Metal	Poly		
<b>Manual Brass Petcock Drain</b>	1/4"	3P-060-M02-DCP	3P-060-P02-DCP	10.0	10.0	8.0	3.9
	3/8"	3P-060-M03-DCP	3P-060-P03-DCP	10.0	10.0	8.0	3.9
	1/2"	3P-060-M04-DCP	3P-060-P04-DCP	10.0	10.0	8.0	3.9
<b>Automatic Float Drain</b>	1/4"	3P-060-M02-DC	3P-060-P02-DC	10.0	10.5	8.0	3.9
	3/8"	3P-060-M03-DC	3P-060-P03-DC	10.0	10.5	8.0	3.9
	1/2"	3P-060-M04-DC	3P-060-P04-DC	10.0	10.5	8.0	3.9

\*To add an indicator, add "i" to end of model number (Indicator adds about 1" to height)



# Specifications

<b>Port Sizes</b>	1/2", 3/4", 1"
<b>Thread Styles</b>	NPT, BSPT, BSPP
<b>Flow Capacity</b>	90/150 scfm @ 100 PSI
<b>Filter Capacity</b>	0.01 Micron & larger
<b>Differential Pressure</b>	< 5.0 PSID at rated flow
<b>Max Temp/ Pressure</b>	
<b>Aluminum Bowl</b>	75 °F/200 PSIG
<b>Max Temp/ Pressure</b>	
<b>Polycarbonate Bowl</b>	125 °F/150 PSIG
<b>Approx. Weight (lb.)</b>	12.0
<b>ISO Class</b>	1 Particulate/Oil

For higher pressure applications, consult factory.  
Units equipped with differential pressure indicator have max temperature and pressure of 125 °F and 150 PSIG, regardless of bowl material.



**Water**  
**Dirt**  
**Oil**  
**Oil Vapor**  
**Odor**

# Replacement Parts & Accessories

Description	Part Number
<b>A</b> Replacement Element, 1st Stage	3P-090/3P-150
<b>B</b> Replacement Element, 2nd Stage	3C-090/3C-150
<b>C</b> Differential Pressure Indicator	N32-W1-DPI
<b>C</b> Blanking Cap (Cover for Indicator)	N32-95-020
<b>D</b> Bowl Assembly: Metal Bowl, Manual Petcock Drain, & O-ring	N34-15-180
<b>D</b> Bowl Assembly: Metal Bowl, Auto Float Drain, & O-ring	N34-15-178
<b>E</b> Bowl Assembly: Poly Bowl, Manual Petcock Drain, & O-ring*	N32-15-167
<b>E</b> Bowl Assembly: Poly Bowl, Auto Float Drain, & O-ring*	N32-15-166
<b>F</b> Manual Petcock Drain (Metal Bowl)	PC-03
<b>F</b> Manual Petcock Drain (Poly Bowl)	N32-95-182
<b>G</b> Automatic Plastic Float Drain (Metal Bowl)	N32-95-979
<b>G</b> Automatic Brass Float Drain (Poly Bowl)	N32-95-978
<b>H</b> Bowl O-ring	N32-95-256

\*Poly bowls come with metal bowl guard

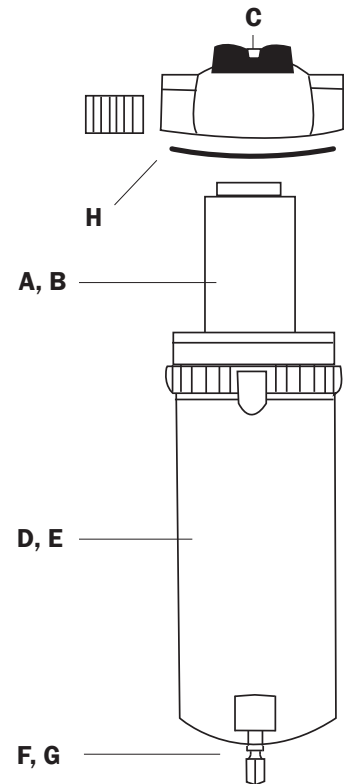

# Order Guide

	Port Size	Model Number				Dimensions (inches)			
		Metal Bowl		Poly Bowl		Height*			
		Low Flow	Med Flow	Low Flow	Med Flow	Metal	Poly	Width	Depth
<b>Manual Brass Petcock Drain</b>	1/2"	3P-090-M04-DCP	3P-150-M04-DCP	3P-090-P04-DCP	3P-150-P04-DCP	17.0	14.0	9.6	4.8
	3/4"	3P-090-M06-DCP	3P-150-M06-DCP	3P-090-P06-DCP	3P-150-P06-DCP	17.0	14.0	9.6	4.8
	1"	3P-090-M08-DCP	3P-150-M08-DCP	3P-090-P08-DCP	3P-150-P08-DCP	17.0	14.0	9.6	4.8
<b>Automatic Float Drain</b>	1/2"	3P-090-M04-DC	3P-150-M04-DC	3P-090-P04-DC	3P-150-P04-DC	17.0	14.5	9.6	4.8
	3/4"	3P-090-M06-DC	3P-150-M06-DC	3P-090-P06-DC	3P-150-P06-DC	17.0	14.5	9.6	4.8
	1"	3P-090-M08-DC	3P-150-M08-DC	3P-090-P08-DC	3P-150-P08-DC	17.0	14.5	9.6	4.8

\*To add an indicator, add "i" to end of model number (Indicator adds about 1" to height)



(800) 521-9200

PDF available at [www.driair.com](http://www.driair.com)

# Specifications

<b>Port Sizes</b>	1/4"
<b>Thread Styles</b>	NPT, BSPT, BSPP
<b>Flow Capacity</b>	20 scfm @ 100 PSI
<b>Filter Capacity</b>	0.01 Micron & larger
<b>Differential Pressure</b>	< 1.5 PSID at rated flow
<b>Max Temp/ Pressure</b>	
<b>Aluminum Bowl</b>	175 °F/200 PSIG
<b>Max Temp/ Pressure</b>	
<b>Polycarbonate Bowl</b>	125 °F/150 PSIG
<b>Approx. Weight (lb.)</b>	2.0
<b>ISO Class</b>	1 Particulate/Oil

For higher pressure applications, consult factory.  
 Units equipped with differential pressure indicator have max temperature and pressure of 125 °F and 150 PSIG, regardless of bowl material.



*Water*  
**Dirt**  
**Oil**  
*Oil Vapor*  
*Odor*

# Replacement Parts & Accessories

Description	Part Number
<b>A</b> Replacement Element	3C-020
<b>B</b> Differential Pressure Indicator	N32-W1-DPI
<b>C</b> Blanking Cap (Cover for Indicator)	N32-95-020
<b>C</b> Bowl Assembly: Metal Bowl, Manual Petcock Drain, & O-ring	N32-95-178
<b>C</b> Bowl Assembly: Metal Bowl, Auto Float Drain, & O-ring	N32-95-950
<b>D</b> Bowl Assembly: Poly Bowl, Manual Petcock Drain, & O-ring*	N32-15-159
<b>D</b> Bowl Assembly: Poly Bowl, Auto Float Drain, & O-ring*	N32-15-160
<b>E</b> Manual Petcock Drain	N32-95-182
<b>F</b> Automatic Plastic Float Drain	N32-95-973
<b>G</b> Bowl O-ring	N32-95-009

\*Poly bowls come with metal bowl guard

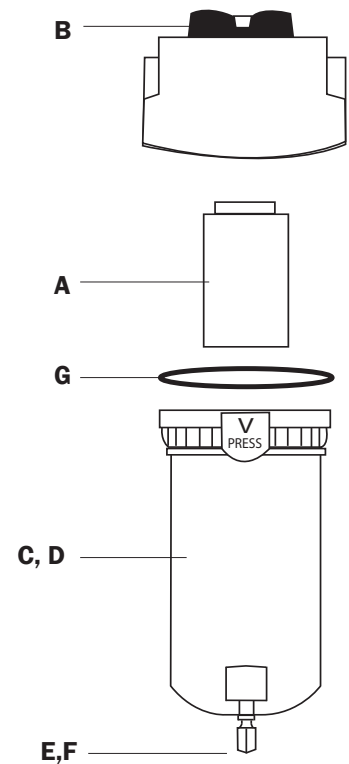

# Order Guide

	Port Size	Model Number		Dimensions (inches)		
		Metal Bowl	Poly Bowl	Height*	Width	Depth
<b>Manual Brass Petcock Drain</b>	1/4"	3C-020-M02-P	3C-020-P02-P	6.8	3.0	2.7
<b>Automatic Float Drain</b>	1/4"	3C-020-M02-F	3C-020-P02-F	6.8	3.0	2.7

\*To add an indicator, add "i" to end of model number (Indicator adds about 1" to height)

# Specifications

<b>Port Sizes</b>	1/4", 3/8", 1/2"
<b>Thread Styles</b>	NPT, BSPT, BSPP
<b>Flow Capacity</b>	60 scfm @ 100 PSI
<b>Filter Capacity</b>	0.01 Micron & larger
<b>Differential Pressure</b>	< 1.5 PSID at rated flow
<b>Max Temp/ Pressure</b>	
<b>Aluminum Bowl</b>	175° F/200 PSIG
<b>Max Temp/ Pressure</b>	
<b>Polycarbonate Bowl</b>	125° F/150 PSIG
<b>Approx. Weight (lb.)</b>	3.5
<b>ISO Class</b>	1 Particulate/Oil

For higher pressure applications, consult factory.  
 Units equipped with differential pressure indicator have max temperature and pressure of 125° F and 150 PSIG, regardless of bowl material.



Water  
 Dirt  
 Oil  
 Oil Vapor  
 Odor

# Replacement Parts & Accessories

Description	Part Number
<b>A</b> Replacement Element	3C-060
<b>B</b> Differential Pressure Indicator	N32-W1-DPI
<b>B</b> Blanking Cap (Cover for Indicator)	N32-95-020
<b>C</b> Bowl Assembly: Metal Bowl, Manual Petcock Drain, & O-ring	N34-95-205
<b>C</b> Bowl Assembly: Metal Bowl, Auto Float Drain, & O-ring	N34-95-201
<b>D</b> Bowl Assembly: Poly Bowl, Manual Petcock Drain, & O-ring*	N32-15-163
<b>D</b> Bowl Assembly: Poly Bowl, Auto Float Drain, & O-ring*	N32-15-164
<b>E</b> Manual Petcock Drain (Metal Bowl)	PC-02
<b>E</b> Manual Petcock Drain (Poly Bowl)	N32-95-182
<b>F</b> Automatic Plastic Float Drain (Metal Bowl)	N32-95-979
<b>F</b> Automatic Brass Float Drain (Poly Bowl)	N32-95-978
<b>G</b> Bowl O-ring	N32-95-257

\*Poly bowls come with metal bowl guard

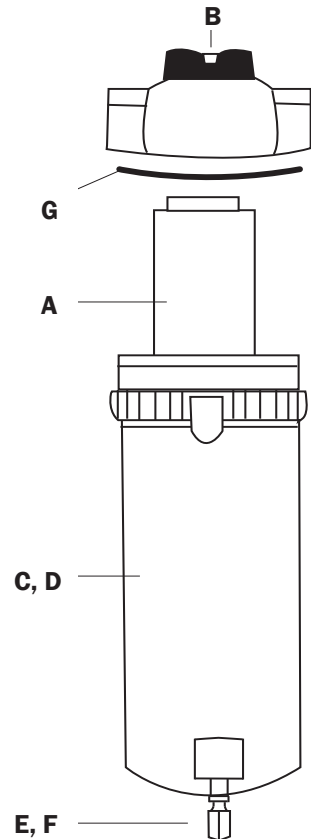

# Order Guide

	Port Size	Model Number	
		Metal Bowl	Poly Bowl
Manual Brass Petcock Drain	1/4"	3C-060-M02-P	3C-060-P02-P
	3/8"	3C-060-M03-P	3C-060-P03-P
	1/2"	3C-060-M04-P	3C-060-P04-P

Automatic Float Drain	1/4"	3C-060-M02-F	3C-060-P02-F
	3/8"	3C-060-M03-F	3C-060-P03-F
	1/2"	3C-060-M04-F	3C-060-P04-F

Dimensions (inches)			
Height*		Width	Depth
Metal	Poly		
10.0	10.0	3.9	3.9
10.0	10.0	3.9	3.9
10.0	10.0	3.9	3.9

10.0	10.5	3.9	3.9
10.0	10.5	3.9	3.9
10.0	10.5	3.9	3.9

\*To add an indicator, add "i" to end of model number (Indicator adds about 1" to height)



(800) 521-9200

PDF available at [www.driair.com](http://www.driair.com)

# Specifications

<b>Port Sizes</b>	1/2", 3/4", 1"
<b>Thread Styles</b>	NPT, BSPT, BSPP
<b>Flow Capacity</b>	90/150/250 scfm @ 100 PSI
<b>Filter Capacity</b>	0.01 Micron & larger
<b>Differential Pressure</b>	< 1.5 PSID at rated flow
<b>Max Temp/ Pressure</b>	
<b>Aluminum Bowl</b>	175 °F/200 PSIG
<b>Max Temp/ Pressure</b>	
<b>Polycarbonate Bowl</b>	125 °F/150 PSIG
<b>Approx. Weight (lb.)</b>	6.0
<b>ISO Class</b>	1 Particulate/Oil

For higher pressure applications, consult factory.  
Units equipped with differential pressure indicator have max temperature and pressure of 125 °F and 150 PSIG, regardless of bowl material.



Water  
Dirt  
Oil  
Oil Vapor  
Odor

	Dimensions (inches)			
	Height*		Width	Depth
	Metal	Poly		
<b>Manual Drain</b>	17.0	14.0	4.6	4.8
<b>Automatic Float Drain</b>	17.0	14.5	4.6	4.8

# Replacement Parts & Accessories

Description	Part Number
<b>A</b> Replacement Element	3C-090/3C-150/3C-250
<b>B</b> Differential Pressure Indicator	N32-W1-DPI
<b>B</b> Blanking Cap (Cover for Indicator)	N32-95-020
<b>C</b> Bowl Assembly: Metal Bowl, Manual Petcock Drain, & O-ring	N34-15-180
<b>C</b> Bowl Assembly: Metal Bowl, Auto Float Drain, & O-ring	N34-15-178
<b>D</b> Bowl Assembly: Poly Bowl, Manual Petcock Drain, & O-ring*	N32-15-167
<b>D</b> Bowl Assembly: Poly Bowl, Auto Float Drain, & O-ring*	N32-15-166
<b>E</b> Manual Petcock Drain (Metal Bowl)	PC-03
<b>E</b> Manual Petcock Drain (Poly Bowl)	N32-95-182
<b>F</b> Automatic Plastic Float Drain (Metal Bowl)	N32-95-979
<b>F</b> Automatic Brass Float Drain (Poly Bowl)	N32-95-978
<b>G</b> Bowl O-ring	N32-95-256

\*Poly bowls come with metal bowl guard

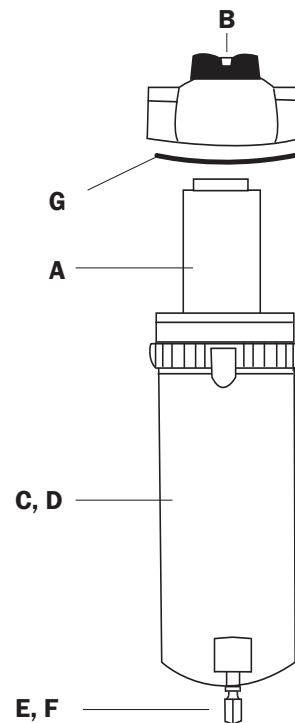

# Order Guide

	Port Size	Model Number				
		Metal Bowl			Poly Bowl	
		Low Flow	Med Flow	High Flow	Low Flow	Med Flow
<b>Manual Brass Petcock Drain</b>	1/2"	3C-090-M04-P	3C-150-M04-P	3C-250-M04-P	3C-090-P04-P	3C-150-P04-P
	3/4"	3C-090-M06-P	3C-150-M06-P	3C-250-M06-P	3C-090-P06-P	3C-150-P06-P
	1"	3C-090-M08-P	3C-150-M08-P	3C-250-M08-P	3C-090-P08-P	3C-150-P08-P
<b>Automatic Float Drain</b>	1/2"	3C-090-M04-F	3C-150-M04-F	3C-250-M04-F	3C-090-P04-F	3C-150-P04-F
	3/4"	3C-090-M06-F	3C-150-M06-F	3C-250-M06-F	3C-090-P06-F	3C-150-P06-F
	1"	3C-090-M08-F	3C-150-M08-F	3C-250-M08-F	3C-090-P08-F	3C-150-P08-F

\*To add an indicator, add "i" to end of model number (Indicator adds about 1" to height)



# Specifications

<b>Port Sizes</b>	1¼", 1½", 2"
<b>Thread Styles</b>	NPT, BSPT, BSPP
<b>Flow Capacity</b>	300/400/700 scfm @ 100 PSI
<b>Filter Capacity</b>	0.01 Micron & larger
<b>Differential Pressure</b>	< 1.5 PSID at rated flow
<b>Max Temp/ Pressure</b>	
<b>Aluminum Bowl</b>	175 °F/200 PSIG
<b>Approx. Weight (lb.)</b>	30.0
<b>ISO Class</b>	1 Particulate/Oil

For higher pressure applications, consult factory.  
 Units equipped with differential pressure indicator have max temperature and pressure of 125 °F and 150 PSIG, regardless of bowl material.



*Water*  
**Dirt**  
**Oil**  
*Oil Vapor*  
*Odor*

# Replacement Parts & Accessories

Description	Part Number
<b>A</b> Replacement Element	3C-300/3C-400/3C-700
<b>B</b> Manual Drain, Ball Valve	BV-051
<b>C</b> Automatic Float Drain	N32-95-XD8
<b>D</b> Bowl O-ring	N32-F35-OR

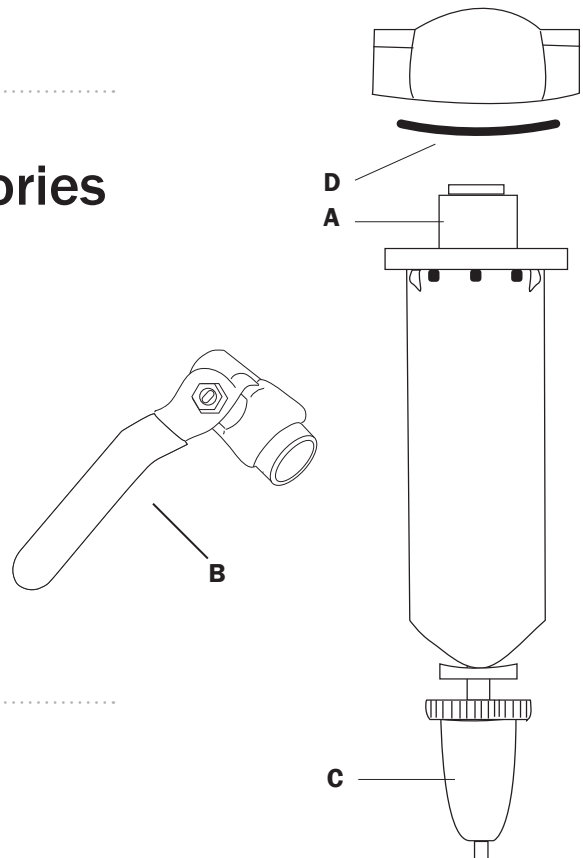

# Order Guide

	Port Size	Model Number			Dimensions (inches)				
		Low Flow	Med Flow	High Flow	Height*			Width	
<b>Manual Ball Valve</b>	1¼"	3C-300-M10-P	3C-400-M10-P	3C-700-M10-P	28.0	28.0	28.0	7.8	7.8
	1½"	3C-300-M12-P	3C-400-M12-P	3C-700-M12-P					
	2"	3C-300-M16-P	3C-400-M16-P	3C-700-M16-P					
<b>External Automatic Float Drain</b>	1¼"	3C-300-M10-F	3C-400-M10-F	3C-700-M10-F	32.0	32.0	32.0	7.8	7.8
	1½"	3C-300-M12-F	3C-400-M12-F	3C-700-M12-F					
	2"	3C-300-M16-F	3C-400-M16-F	3C-700-M16-F					

\*To add an indicator, add "I" to end of model number (Indicator adds about 1" to height)



(800) 521-9200

PDF available at [www.driair.com](http://www.driair.com)

# Specifications

<b>Port Sizes</b>	3"
<b>Connection</b>	NPT, BSPT, BSPP
<b>Flow Capacity</b>	1200 scfm @ 100 PSI
<b>Filter Capacity</b>	0.01 Micron & larger
<b>Differential Pressure</b>	< 1.5 PSID at rated flow
<b>Max Temp/ Pressure</b>	
<b>Manual Drain</b>	175° F/200 PSIG
<b>Max Temp/Pressure</b>	
<b>Float Drain</b>	125° F/150 PSIG
<b>Approx. Weight (lb.)</b>	38.0
<b>ISO Class</b>	1 Particulate/Oil

For higher pressure units, consult factory.



*Water*  
**Dirt**  
**Oil**  
*Oil Vapor*  
*Odor*

# Replacement Parts & Accessories

Description	Part Number
<b>A</b> Replacement Element	3C-1200
<b>B</b> Manual Drain, Ball Valve	BV-051
<b>C</b> External Float Drain	N32-95-XD8
<b>D</b> Bowl O-ring	PHC-032

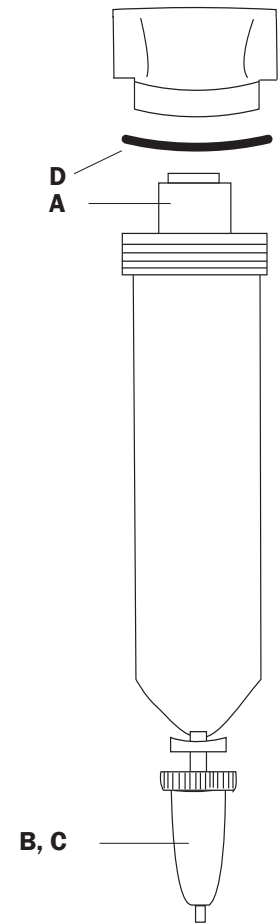

# Order Guide

	Port Size	Model Number	Dimensions (inches)		
			Height	Width	Depth
Manual Brass Petcock Drain	3"	3C-1200-M24-P	40.0	8.0	7.3
Automatic Float Drain	3"	3C-1200-M24-F	44.0	8.0	7.3

# Specifications

<b>Port Sizes</b>	3", 4", 6" RFSO
<b>Connection</b>	Raised face 150# Flange
<b>Flow Capacity</b>	1900/3000 scfm @ 100 PSI
<b>Filter Capacity</b>	0.01 Micron & larger
<b>Differential Pressure</b>	< 1.5 PSID at rated flow
<b>Max Temp/ Pressure</b>	
<b>Epoxy Coated</b>	
<b>Carbon Steel</b>	150°F/200 PSIG
<b>Approx. Weight (lb.)</b>	280/290/420
<b>ISO Class</b>	1 Particulate/Oil

For higher pressure applications, consult factory.  
 Units equipped with external auto drain  
 have max temperature and pressure of 150 °F  
 and 150 PSIG.



*Water*  
**Dirt**  
**Oil**  
*Oil Vapor*  
*Odor*

# Replacement Parts & Accessories

	<b>Description</b>	<b>Part Number</b>
<b>A</b>	Replacement Element	3C-1900/3C-3000
<b>B</b>	Differential Pressure Indicator	N32-P2-DPi
<b>C</b>	Manual Drain, Ball Valve	BV-051
<b>D</b>	External Float Drain	N32-95-XD8

Note:  
 All 3C-1900 units require a minimum of 25" clearance between  
 bottom of housing and floor for installation.  
 All 3C-3000 units require a minimum of 36" clearance between  
 bottom of housing and floor for installation.

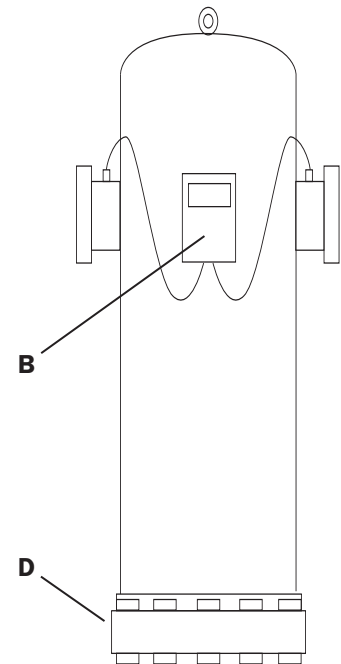

# Order Guide

	Port Size	Model Number	Dimensions (inches)		
			Height	Width	Depth
<b>Manual Brass Petcock Drain</b>	3"	3C-1900-MFD-P	50.2	20.0	16.0
	4"	3C-1900-MFE-P	50.2	20.0	16.0
	6"	3C-3000-MFF-P	50.2	23.4	19.0
<b>Automatic Float Drain</b>	3"	3C-1900-MFD-X	50.2	20.0	16.0
	4"	3C-1900-MFE-X	50.2	20.0	16.0
	6"	3C-3000-MFF-X	50.2	23.4	19.0

Dimensions (inches)		
Height	Width	Depth
50.2	20.0	16.0
50.2	20.0	16.0
50.2	23.4	19.0
50.2	20.0	16.0
50.2	20.0	16.0
50.2	23.4	19.0

Indicator included as standard with these metal bowl units.



(800) 521-9200

PDF available at [www.driair.com](http://www.driair.com)

# Specifications

<b>Port Sizes</b>	1/4", 3/8", 1/2"
<b>Thread Styles</b>	NPT, BSPT, BSPP
<b>Flow Capacity</b>	60 scfm @ 100 PSI
<b>Filter Capacity</b>	1.0 Micron & larger Activated Carbon Oil Adsorption to 0.003 ppm < 3.0 PSID at rated flow
<b>Differential Pressure</b>	
<b>Max Temp/ Pressure</b>	
<b>Aluminum Bowl</b>	175 °F/200 PSIG
<b>Max Temp/ Pressure</b>	
<b>Polycarbonate Bowl</b>	125 °F/150 PSIG
<b>Approx. Weight (lb.)</b>	3.5
<b>ISO Class</b>	2 Particulate/Oil

For higher pressure applications, consult factory.  
Units equipped with differential pressure indicator have max temperature and pressure of 125 °F and 150 PSIG, regardless of bowl material.



# Replacement Parts & Accessories

Description	Part Number
<b>A</b> Replacement Element	4P-060
<b>B</b> Differential Pressure Indicator	N32-W1-DPI
<b>B</b> Blanking Cap (Cover for Indicator)	N32-95-020
<b>C</b> Bowl Assembly: Metal Bowl, Manual Petcock Drain, & O-ring	N34-95-205
<b>C</b> Bowl Assembly: Metal Bowl, Auto Float Drain, & O-ring	N34-95-201
<b>D</b> Bowl Assembly: Poly Bowl, Manual Petcock Drain, & O-ring*	N32-15-163
<b>D</b> Bowl Assembly: Poly Bowl, Auto Float Drain, & O-ring*	N32-15-164
<b>E</b> Manual Petcock Drain (Metal Bowl)	PC-02
<b>E</b> Manual Petcock Drain (Poly Bowl)	N32-95-182
<b>F</b> Automatic Plastic Float Drain (Metal Bowl)	N32-95-979
<b>F</b> Automatic Brass Float Drain (Poly Bowl)	N32-95-978
<b>G</b> Bowl O-ring	N32-95-257

\*Poly bowls come with metal bowl guard

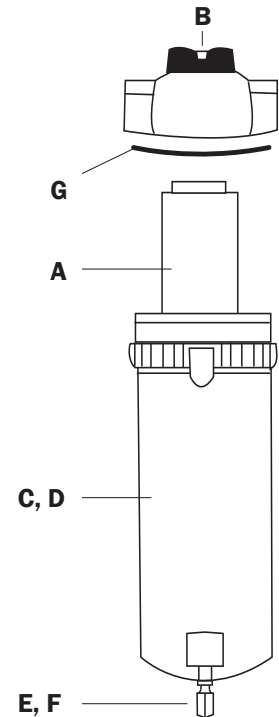

# Order Guide

	Port Size	Model Number		Dimensions (inches)			
		Metal Bowl	Poly Bowl	Height*		Width	Depth
				Metal	Poly		
Manual Brass Petcock Drain	1/4"	4P-060-M02-P	4P-060-P02-P	10.0	10.0	3.9	3.9
	3/8"	4P-060-M03-P	4P-060-P03-P	10.0	10.0	3.9	3.9
	1/2"	4P-060-M04-P	4P-060-P04-P	10.0	10.0	3.9	3.9
Automatic Float Drain	1/4"	4P-060-M02-F	4P-060-P02-F	10.0	10.5	3.9	3.9
	3/8"	4P-060-M03-F	4P-060-P03-F	10.0	10.5	3.9	3.9
	1/2"	4P-060-M04-F	4P-060-P04-F	10.0	10.5	3.9	3.9

\*To add an indicator, add "i" to end of model number (Indicator adds about 1" to height)



# Specifications

<b>Port Sizes</b>	½", ¾", 1"
<b>Thread Styles</b>	NPT, BSPT, BSPP
<b>Flow Capacity</b>	90/150 scfm @ 100 PSI
<b>Filter Capacity</b>	1.0 Micron & larger Activated Carbon Oil Adsorption to 0.003 ppm < 3.0 PSID at rated flow
<b>Differential Pressure</b>	
<b>Max Temp/ Pressure</b>	
<b>Aluminum Bowl</b>	175°F/200 PSIG
<b>Max Temp/ Pressure</b>	
<b>Polycarbonate Bowl</b>	125°F/150 PSIG
<b>Approx. Weight (lb.)</b>	6.0
<b>ISO Class</b>	2 Particulate/Oil

For higher pressure applications, consult factory.  
Units equipped with differential pressure indicator have max temperature and pressure of 125°F and 150 PSIG, regardless of bowl material.



**Water**  
**Dirt**  
**Oil**  
**Oil Vapor**  
**Odor**

# Replacement Parts & Accessories

Description	Part Number
<b>A</b> Replacement Element	4P-090/4P-150
<b>B</b> Differential Pressure Indicator	N32-W1-DPI
<b>B</b> Blanking Cap (Cover for Indicator)	N32-95-020
<b>C</b> Bowl Assembly: Metal Bowl, Manual Petcock Drain, & O-ring	N34-15-180
<b>C</b> Bowl Assembly: Metal Bowl, Auto Float Drain, & O-ring	N34-15-178
<b>D</b> Bowl Assembly: Poly Bowl, Manual Petcock Drain, & O-ring*	N32-15-167
<b>D</b> Bowl Assembly: Poly Bowl, Auto Float Drain, & O-ring*	N32-15-166
<b>E</b> Manual Petcock Drain (Metal Bowl)	PC-03
<b>E</b> Manual Petcock Drain (Poly Bowl)	N32-95-182
<b>F</b> Automatic Plastic Float Drain (Metal Bowl)	N32-95-979
<b>F</b> Automatic Brass Float Drain (Poly Bowl)	N32-95-978
<b>G</b> Bowl O-ring	N32-95-256

\*Poly bowls come with metal bowl guard

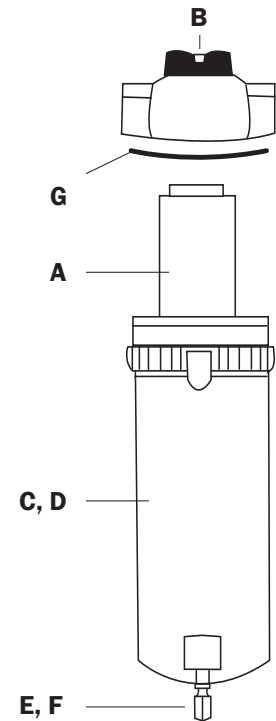

# Order Guide

	Port Size	Model Number				Dimensions (inches)			
		Metal Bowl		Poly Bowl		Height*		Width	Depth
		Low Flow	Med Flow	Low Flow	Med Flow	Metal	Poly		
<b>Manual Brass Petcock Drain</b>	½"	4P-090-M04-P	4P-150-M04-P	4P-090-P04-P	4P-150-P04-P	17.0	14.0	4.6	4.8
	¾"	4P-090-M06-P	4P-150-M06-P	4P-090-P06-P	4P-150-P06-P	17.0	14.0	4.6	4.8
	1"	4P-090-M08-P	4P-150-M08-P	4P-090-P08-P	4P-150-P08-P	17.0	14.0	4.6	4.8
<b>Automatic Float Drain</b>	½"	4P-090-M04-F	4P-150-M04-F	4P-090-P04-F	4P-150-P04-F	17.0	14.5	4.6	4.8
	¾"	4P-090-M06-F	4P-150-M06-F	4P-090-P06-F	4P-150-P06-F	17.0	14.5	4.6	4.8
	1"	4P-090-M08-F	4P-150-M08-F	4P-090-P08-F	4P-150-P08-F	17.0	14.5	4.6	4.8

\*To add an indicator, add "i" to end of model number (Indicator adds about 1" to height)



(800) 521-9200

PDF available at [www.driair.com](http://www.driair.com)

# Specifications

<b>Port Sizes</b>	1/4", 3/8", 1/2"
<b>Thread Styles</b>	NPT, BSPT, BSPP
<b>Flow Capacity</b>	60 scfm @ 100 PSI
<b>Filter Capacity</b>	0.01 Micron & larger
	Activated Carbon Oil
	Adsorption to 0.003 ppm Hydrocarbons
	< 5.0 PSID at rated flow
<b>Differential Pressure</b>	
<b>Max Temp/ Pressure</b>	
<b>Aluminum Bowl</b>	175 °F/200 PSIG
<b>Max Temp/ Pressure</b>	
<b>Polycarbonate Bowl</b>	125 °F/150 PSIG
<b>Approx. Weight (lb.)</b>	7.0
<b>ISO Class</b>	1 Particulate/Oil

For higher pressure applications, consult factory.  
Units equipped with differential pressure indicator have max temperature and pressure of 125 °F and 150 PSIG, regardless of bowl material.



**Water**  
**Dirt**  
**Oil**  
**Oil Vapor**  
**Odor**

# Replacement Parts & Accessories

Description	Part Number
<b>A</b> Replacement Element, 1st Stage	4P-060
<b>B</b> Replacement Element, 2nd Stage	3C-060
<b>C</b> Differential Pressure Indicator	N32-W1-DPI
<b>C</b> Blanking Cap (Cover for Indicator)	N32-95-020
<b>D</b> Bowl Assembly: Metal Bowl, Manual Petcock Drain, & O-ring	N34-95-205
<b>D</b> Bowl Assembly: Metal Bowl, Auto Float Drain, & O-ring	N32-95-201
<b>E</b> Bowl Assembly: Poly Bowl, Manual Petcock Drain, & O-ring*	N32-15-163
<b>E</b> Bowl Assembly: Poly Bowl, Auto Float Drain, & O-ring*	N32-15-164
<b>F</b> Manual Petcock Drain (Metal Bowl)	PC-02
<b>F</b> Manual Petcock Drain (Poly Bowl)	N32-95-182
<b>G</b> Automatic Plastic Float Drain (Metal Bowl)	N32-95-979
<b>G</b> Automatic Brass Float Drain (Poly Bowl)	N32-95-978
<b>H</b> Bowl O-ring	N32-95-257

\*Poly bowls come with metal bowl guard

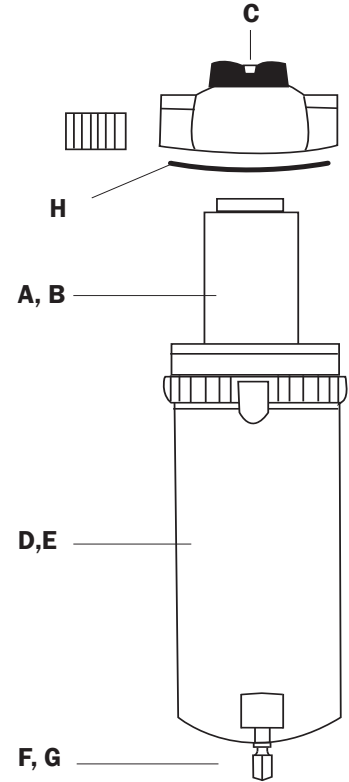

# Order Guide

	Port Size	Model Number	
		Metal Bowl	Poly Bowl
<b>Manual Brass Petcock Drain</b>	1/4"	4P-060-M02-DCP	4P-060-P02-DCP
	3/8"	4P-060-M03-DCP	4P-060-P03-DCP
	1/2"	4P-060-M04-DCP	4P-060-P04-DCP
<b>Automatic Float Drain</b>	1/4"	4P-060-M02-DC	4P-060-P02-DC
	3/8"	4P-060-M03-DC	4P-060-P03-DC
	1/2"	4P-060-M04-DC	4P-060-P04-DC

Dimensions (inches)			
Height*		Width	Depth
Metal	Poly		
10.0	10.0	8.0	3.9
10.0	10.0	8.0	3.9
10.0	10.0	8.0	3.9
10.0	10.5	8.0	3.9
10.0	10.5	8.0	3.9
10.0	10.5	8.0	3.9

\*To add an indicator, add "I" to end of model number (Indicator adds about 1" to height)



# Specifications

<b>Port Sizes</b>	1/2", 3/4", 1"
<b>Thread Styles</b>	NPT, BSPT, BSPP
<b>Flow Capacity</b>	90/150 scfm @ 100 PSI
<b>Filter Capacity</b>	0.01 Micron & larger
	Activated Carbon Oil
	Adsorption to 0.003 ppm
	< 5.0 PSID at rated flow
<b>Differential Pressure</b>	
<b>Max Temp/ Pressure</b>	
<b>Aluminum Bowl</b>	175° F/200 PSIG
<b>Max Temp/ Pressure</b>	
<b>Polycarbonate Bowl</b>	125° F/150 PSIG
<b>Approx. Weight (lb.)</b>	12.0
<b>ISO Class</b>	1 Particulate/Oil

For higher pressure applications, consult factory.  
Units equipped with differential pressure indicator have max temperature and pressure of 125° F and 150 PSIG, regardless of bowl material.



**Water**  
**Dirt**  
**Oil**  
**Oil Vapor**  
**Odor**

# Replacement Parts & Accessories

Description	Part Number
<b>A</b> Replacement Element, 1st Stage	4P-090/4P-150
<b>B</b> Replacement Element, 2nd Stage	3C-090/3C-150
<b>C</b> Differential Pressure Indicator	N32-W1-DPI
<b>C</b> Blanking Cap (Cover for Indicator)	N32-95-020
<b>D</b> Bowl Assembly: Metal Bowl, Manual Petcock Drain, & O-ring	N34-15-180
<b>D</b> Bowl Assembly: Metal Bowl, Auto Float Drain, & O-ring	N34-15-178
<b>E</b> Bowl Assembly: Poly Bowl, Manual Petcock Drain, & O-ring*	N32-15-167
<b>E</b> Bowl Assembly: Poly Bowl, Auto Float Drain, & O-ring*	N32-15-166
<b>F</b> Manual Petcock Drain (Metal Bowl)	PC-03
<b>F</b> Manual Petcock Drain (Poly Bowl)	N32-95-182
<b>G</b> Automatic Plastic Float Drain (Metal Bowl)	N32-95-979
<b>G</b> Automatic Brass Float Drain (Poly Bowl)	N32-95-978
<b>H</b> Bowl O-ring	N32-95-256

\*Poly bowls come with metal bowl guard

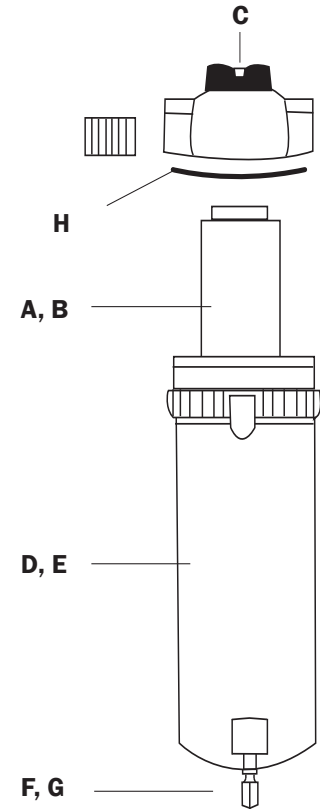

# Order Guide

	Port Size	Model Number				Dimensions (inches)			
		Metal Bowl		Poly Bowl		Height*		Width	Depth
		Low Flow	Med Flow	Low Flow	Med Flow	Metal	Poly		
<b>Manual Brass Petcock Drain</b>	1/2"	4P-090-M04-DCP	4P-150-M04-DCP	4P-090-P04-DCP	4P-150-P04-DCP	17.0	14.0	10.0	4.8
	3/4"	4P-090-M06-DCP	4P-150-M06-DCP	4P-090-P06-DCP	4P-150-P06-DCP	17.0	14.0	10.0	4.8
	1"	4P-090-M08-DCP	4P-150-M08-DCP	4P-090-P08-DCP	4P-150-P08-DCP	17.0	14.0	10.0	4.8
<b>Automatic Float Drain</b>	1/2"	4P-090-M04-DC	4P-150-M04-DC	4P-090-P04-DC	4P-150-P04-DC	17.0	14.5	10.0	4.8
	3/4"	4P-090-M06-DC	4P-150-M06-DC	4P-090-P06-DC	4P-150-P06-DC	17.0	14.5	10.0	4.8
	1"	4P-090-M08-DC	4P-150-M08-DC	4P-090-P08-DC	4P-150-P08-DC	17.0	14.5	10.0	4.8

\*To add an indicator, add "i" to end of model number (Indicator adds about 1" to height)



(800) 521-9200

PDF available at [www.driair.com](http://www.driair.com)

# Specifications

<b>Port Sizes</b>	3/8", 1/2", 3/4", 1"
<b>Thread Styles</b>	NPT, BSPT, BSPP
<b>Flow Capacity</b>	60/120/175 scfm @ 100 PSI
<b>Filter Capacity</b>	3.0 Micron & larger
<b>Differential Pressure</b>	< 5.0 PSID at rated flow
<b>Max Temp/ Pressure</b>	
<b>Aluminum Bowl</b>	175 °F/200 PSIG
<b>Approx. Weight (lb.)</b>	3.5/6.0/6.0
<b>ISO Class</b>	3 Particulate

For higher pressure applications, consult factory.  
Units equipped with differential pressure indicator have max temperature and pressure of 125 °F and 150 PSIG, regardless of bowl material.

Food Grade certified non-toxic powder coated filters meet requirements of 21 CFR 100. Coating ingredients meet at least one section of FDA Title 21, with the exception of food items containing 8% alcohol.

**Water**  
**Dirt**  
**Oil**  
**Oil Vapor**  
**Odor**



# Replacement Parts & Accessories

Description	Part Number
<b>A</b> Replacement Element, 1st Stage	1P-060/1P-120/1P-175
<b>B</b> Differential Pressure Indicator	N32-W1-DPI-FG
<b>B</b> Blanking Cap (Cover for Indicator)	N32-95-020-FG
<b>C</b> Bowl Assembly: Metal Bowl, Manual Petcock Drain, & O-ring (60)	N34-95-205-FG
<b>C</b> Bowl Assembly: Metal Bowl, Auto Float Drain, & O-ring (60)	N34-95-195-FG
<b>C</b> Bowl Assembly: Metal Bowl, Manual Petcock Drain, & O-ring (120/175)	N34-15-180-FG
<b>C</b> Bowl Assembly: Metal Bowl, Auto Float Drain, & O-ring (120/175)	N34-15-185-FG
<b>D</b> Manual Petcock Drain	PC-03
<b>E</b> Automatic Float Drain	N32-95-973-FG
<b>F</b> Bowl O-ring (60)	N32-95-257
<b>F</b> Bowl O-ring (120/175)	N32-95-256

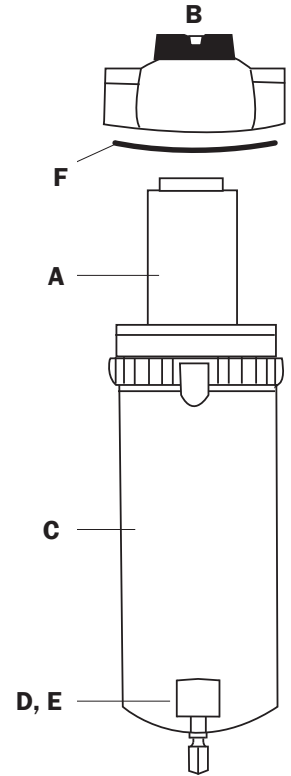

# Order Guide

	Port Size	Model Number
<b>Manual Brass Petcock Drain</b>	3/8"	1P-060-F03-P
	1/2"	1P-060-F04-P
	3/4"	1P-120-F06-P
	1"	1P-175-F08-P

<b>Automatic Plastic Float Drain</b>	3/8"	1P-060-F03-F
	1/2"	1P-060-F04-F
	3/4"	1P-120-F06-F
	1"	1P-175-F08-F

Dimensions (inches)		
Height*	Width	Depth
10.0	3.9	3.9
10.0	3.9	3.9
17.0	4.6	4.8
17.0	4.6	4.8

10.0	3.9	3.9
10.0	3.9	3.9
17.0	4.6	4.8
17.0	4.6	4.8

\*To add an indicator, add "i" to end of model number (Indicator adds about 1" to height)



# Specifications

<b>Port Sizes</b>	3/8", 1/2", 3/4", 1"
<b>Thread Styles</b>	NPT, BSPT, BSPP
<b>Flow Capacity</b>	60/90/150 scfm @ 100 PSI
<b>Filter Capacity</b>	0.01 Micron & larger
<b>Differential Pressure</b>	< 5.0 PSID at rated flow
<b>Max Temp/ Pressure</b>	
<b>Aluminum Bowl</b>	175 °F/200 PSIG
<b>Approx. Weight (lb.)</b>	6.0/12.0/12.0
<b>ISO Class</b>	1 Particulate/Oil

For higher pressure applications, consult factory.  
Units equipped with differential pressure indicator have max temperature and pressure of 125 °F and 150 PSIG, regardless of bowl material.

Food Grade certified non-toxic powder coated filters meet requirements of 21 CFR 100. Coating ingredients meet at least one section of FDA Title 21, with the exception of food items containing 8% alcohol.

**Water**  
**Dirt**  
**Oil**  
**Oil Vapor**  
**Odor**



# Replacement Parts & Accessories

Description	Part Number
<b>A</b> Replacement Element, 1st Stage	1P-060/1P-090/1P-150
<b>B</b> Replacement Element, 2nd Stage (Combo Unit)	3C-060/3C-090/3C-150
<b>C</b> Differential Pressure Indicator	N32-W1-DPI-FG
<b>C</b> Blanking Cap (Cover for Indicator)	N32-95-020-FG
<b>D</b> Bowl Assembly: Metal Bowl, Manual Petcock Drain, & O-ring (60)	N34-95-205-FG
<b>D</b> Bowl Assembly: Metal Bowl, Auto Float Drain, & O-ring (60)	N34-95-195-FG
<b>D</b> Bowl Assembly: Metal Bowl, Manual Petcock Drain, & O-ring (90/150)	N34-15-180-FG
<b>D</b> Bowl Assembly: Metal Bowl, Auto Float Drain, & O-ring (90/150)	N34-15-185-FG
<b>E</b> Manual Petcock Drain	PC-03
<b>F</b> Automatic Float Drain	N32-95-973-FG
<b>G</b> Bowl O-ring (60)	N32-95-257
<b>G</b> Bowl O-ring (90/150)	N32-95-256

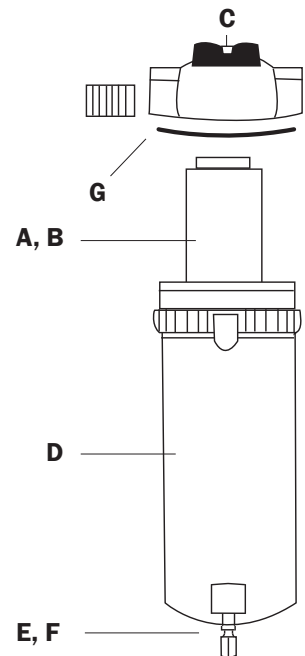

# Order Guide

	Port Size	Model Number
<b>Manual Brass Petcock Drain</b>	3/8"	1P-060-F03-DCP
	1/2"	1P-060-F04-DCP
	3/4"	1P-090-F06-DCP
	1"	1P-150-F08-DCP
<b>Automatic Plastic Float Drain</b>	3/8"	1P-060-F03-DC
	1/2"	1P-060-F04-DC
	3/4"	1P-090-F06-DC
	1"	1P-150-F08-DC

Dimensions (inches)		
Height*	Width	Depth
10.0	8.0	3.9
10.0	8.0	3.9
17.0	10.0	4.8
17.0	10.0	4.8
10.0	8.0	3.9
10.0	8.0	3.9
17.0	10.0	4.8
17.0	10.0	4.8

\*To add an indicator, add "i" to end of model number (Indicator adds about 1" to height)



(800) 521-9200

PDF available at [www.driair.com](http://www.driair.com)

# Specifications

<b>Port Sizes</b>	3/8", 1/2", 3/4", 1"
<b>Thread Styles</b>	NPT, BSPT, BSPP
<b>Flow Capacity</b>	60/90/150 scfm @ 100 PSI
<b>Filter Capacity</b>	1.0 Micron & larger
<b>Differential Pressure</b>	< 5.0 PSID at rated flow
<b>Max Temp/ Pressure</b>	
<b>Aluminum Bowl</b>	175 °F/200 PSIG
<b>Approx. Weight (lb.)</b>	3.5/6.0/6.0
<b>ISO Class</b>	2 Particulate

For higher pressure applications, consult factory.  
Units equipped with differential pressure indicator have max temperature and pressure of 125 °F and 150 PSIG, regardless of bowl material.

Food Grade certified non-toxic powder coated filters meet requirements of 21 CFR 100. Coating ingredients meet at least one section of FDA Title 21, with the exception of food items containing 8% alcohol.

**Water**  
**Dirt**  
**Oil**  
**Oil Vapor**  
**Odor**



# Replacement Parts & Accessories

Description	Part Number
<b>A</b> Replacement Element, 1st Stage	3P-060/3P-090/3P-150
<b>B</b> Differential Pressure Indicator	N32-W1-DPI-FG
<b>B</b> Blanking Cap (Cover for Indicator)	N32-95-020-FG
<b>C</b> Bowl Assembly: Metal Bowl, Manual Petcock Drain, & O-ring (60)	N34-95-205-FG
<b>C</b> Bowl Assembly: Metal Bowl, Auto Float Drain, & O-ring (60)	N34-95-195-FG
<b>C</b> Bowl Assembly: Metal Bowl, Manual Petcock Drain, & O-ring (90/150)	N34-15-180-FG
<b>C</b> Bowl Assembly: Metal Bowl, Auto Float Drain, & O-ring (90/150)	N34-15-185-FG
<b>D</b> Manual Petcock Drain	PC-03
<b>E</b> Automatic Float Drain	N32-95-973-FG
<b>F</b> Bowl O-ring (60)	N32-95-257
<b>F</b> Bowl O-ring (90/150)	N32-95-256

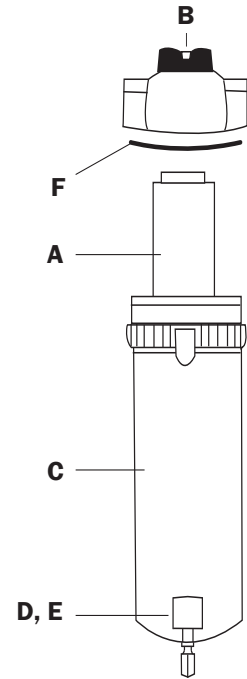

# Order Guide

	Port Size	Model Number
<b>Manual Brass Petcock Drain</b>	3/8"	3P-060-F03-P
	1/2"	3P-060-F04-P
	3/4"	3P-090-F06-P
	1"	3P-150-F08-P

	Port Size	Model Number
<b>Automatic Plastic Float Drain</b>	3/8"	3P-060-F03-F
	1/2"	3P-060-F04-F
	3/4"	3P-090-F06-F
	1"	3P-150-F08-F

Dimensions (inches)		
Height*	Width	Depth
10.0	3.9	3.9
10.0	3.9	3.9
17.0	4.6	4.8
17.0	4.6	4.8

10.5	3.9	3.9
10.5	3.9	3.9
17.0	4.6	4.8
17.0	4.6	4.8

\*To add an indicator, add "i" to end of model number (Indicator adds about 1" to height)

# Specifications

<b>Port Sizes</b>	3/8", 1/2", 3/4", 1"
<b>Thread Styles</b>	NPT, BSPT, BSPP
<b>Flow Capacity</b>	60/90/150 scfm @ 100 PSI
<b>Filter Capacity</b>	0.01 Micron & larger Activated Carbon Oil Adsorption to 0.003 ppm
<b>Differential Pressure</b>	< 5.0 PSID at rated flow
<b>Max Temp/ Pressure</b>	175 °F/200 PSIG
<b>Aluminum Bowl</b>	
<b>Approx. Weight (lb.)</b>	7.0/12.0/12.0
<b>ISO Class</b>	1 Particulate/Oil

For higher pressure applications, consult factory.  
Units equipped with differential pressure indicator have max temperature and pressure of 125 °F and 150 PSIG, regardless of bowl material.

Food Grade certified non-toxic powder coated filters meet requirements of 21 CFR 100. Coating ingredients meet at least one section of FDA Title 21, with the exception of food items containing 8% alcohol.

**Water**  
**Dirt**  
**Oil**  
**Oil Vapor**  
**Odor**



# Replacement Parts & Accessories

Description	Part Number
<b>A</b> Replacement Element, 1st Stage	3P-060/3P-090/3P-150
<b>B</b> Replacement Element, 2nd Stage (Combo Unit)	3C-060/3C-090/3C-150
<b>C</b> Differential Pressure Indicator	N32-W1-DPI-FG
<b>C</b> Blanking Cap (Cover for Indicator)	N32-95-020-FG
<b>D</b> Bowl Assembly: Metal Bowl, Manual Petcock Drain, & O-ring (60)	N34-95-205-FG
<b>D</b> Bowl Assembly: Metal Bowl, Auto Float Drain, & O-ring (60)	N34-95-195-FG
<b>D</b> Bowl Assembly: Metal Bowl, Manual Petcock Drain, & O-ring (90/150)	N34-15-180-FG
<b>D</b> Bowl Assembly: Metal Bowl & Auto Float Drain (90/150)	N34-15-185-FG
<b>E</b> Manual Petcock Drain	PC-03
<b>F</b> Automatic Float Drain	N32-95-973-FG
<b>G</b> Bowl O-ring (60)	N32-95-257
<b>G</b> Bowl O-ring (90/150)	N32-95-256

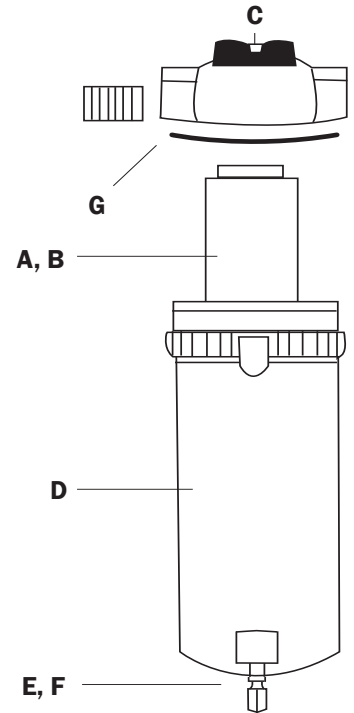

# Order Guide

	Port Size	Model Number
<b>Manual Brass Petcock Drain</b>	3/8"	3P-060-F03-DCP
	1/2"	3P-060-F04-DCP
	3/4"	3P-090-F06-DCP
	1"	3P-150-F08-DCP

	Port Size	Model Number
<b>Automatic Plastic Float Drain</b>	3/8"	3P-060-F03-DC
	1/2"	3P-060-F04-DC
	3/4"	3P-090-F06-DC
	1"	3P-150-F08-DC

Dimensions (inches)		
Height*	Width	Depth
10.0	8.0	3.9
10.0	8.0	3.9
17.0	10.0	4.8
17.0	10.0	4.8

10.5	8.0	3.9
10.5	8.0	3.9
17.0	10.0	4.8
17.0	10.0	4.8

\*To add an indicator, add "i" to end of model number (Indicator adds about 1" to height)



(800) 521-9200

PDF available at [www.driair.com](http://www.driair.com)



# Specifications

<b>Port Sizes</b>	3/8", 1/2", 3/4", 1"
<b>Thread Styles</b>	NPT, BSPT, BSPP
<b>Flow Capacity</b>	60/90/150 scfm @ 100 PSI
<b>Filter Capacity</b>	0.01 Micron & larger Activated Carbon Oil Adsorption to 0.003 ppm < 5.0 PSID at rated flow
<b>Differential Pressure</b>	
<b>Max Temp/ Pressure</b>	175 °F/200 PSIG
<b>Aluminum Bowl</b>	7.0/12.0/12.0
<b>Approx. Weight (lb.)</b>	1 Particulate/Oil
<b>ISO Class</b>	

For higher pressure applications, consult factory. Units equipped with differential pressure indicator have max temperature and pressure of 125 °F and 150 PSIG, regardless of bowl material.

Food Grade certified non-toxic powder coated filters meet requirements of 21 CFR 100. Coating ingredients meet at least one section of FDA Title 21, with the exception of food items containing 8% alcohol.

**Water**  
**Dirt**  
**Oil**  
**Oil Vapor**  
**Odor**



# Replacement Parts & Accessories

Description	Part Number
<b>A</b> Replacement Element, 1st Stage	4P-060/4P-090/4P-150
<b>B</b> Replacement Element, 2nd Stage	3C-060/3C-090/3C-150
<b>C</b> Differential Pressure Indicator	N32-W1-DPI-FG
<b>C</b> Blanking Cap (Cover for Indicator)	N32-95-020-FG
<b>D</b> Bowl Assembly: Metal Bowl, Manual Petcock Drain, & O-ring (60)	N34-95-205-FG
<b>D</b> Bowl Assembly: Metal Bowl, Auto Float Drain, & O-ring (60)	N34-95-195-FG
<b>D</b> Bowl Assembly: Metal Bowl, Manual Petcock Drain, & O-ring (90/150)	N34-15-180-FG
<b>D</b> Bowl Assembly: Metal Bowl, Auto Float Drain, & O-ring (90/150)	N34-15-185-FG
<b>E</b> Manual Petcock Drain	PC-03
<b>F</b> Automatic Float Drain	N32-95-973-FG
<b>G</b> Bowl O-ring (60)	N32-95-257
<b>G</b> Bowl O-ring (90/150)	N32-95-256

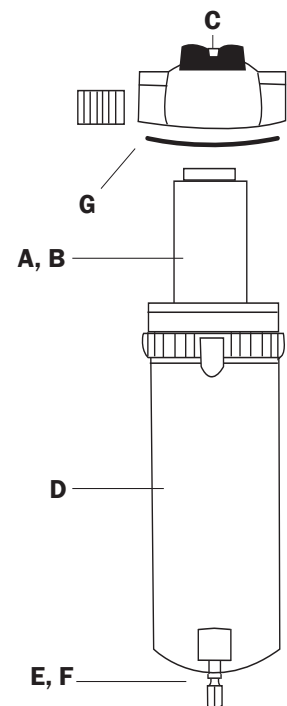

# Order Guide

	Port Size	Model Number	Dimensions (inches)		
			Height*	Width	Depth
<b>Manual Brass Petcock Drain</b>	3/8"	4P-060-F03-DCP	10.0	8.0	3.9
	1/2"	4P-060-F04-DCP	10.0	8.0	3.9
	3/4"	4P-090-F06-DCP	17.0	10.0	4.8
	1"	4P-150-F08-DCP	17.0	10.0	4.8
<b>Automatic Plastic Float Drain</b>	3/8"	4P-060-F03-DC	10.5	8.0	3.9
	1/2"	4P-060-F04-DC	10.5	8.0	3.9
	3/4"	4P-090-F06-DC	17.0	10.0	4.8
	1"	4P-150-F08-DC	17.0	10.0	4.8

\*To add an indicator, add "i" to end of model number (Indicator adds about 1" to height)





# Specifications

<b>Port Sizes</b>	3/8", 1/2", 3/4", 1"
<b>Thread Styles</b>	NPT
<b>Flow Capacity</b>	60/90/150 scfm @ 100 PSI
<b>Filter Capacity</b>	0.01 Micron & larger
<b>Differential Pressure</b>	< 1.5 PSID at rated flow
<b>Max Temp/ Pressure</b>	
<b>Aluminum Bowl</b>	125 °F/150 PSIG
<b>Approx. Weight (lb.)</b>	3.5/6.0/6.0
<b>ISO Class</b>	1 Particulate/Oil

For higher pressure applications, consult factory.  
Units equipped with differential pressure indicator have max temperature and pressure of 125 °F and 150 PSIG, regardless of bowl material.

Food Grade certified non-toxic powder coated filters meet requirements of 21 CFR 100. Coating ingredients meet at least one section of FDA Title 21, with the exception of food items containing 8% alcohol.

Water  
Dirt  
Oil  
Oil Vapor  
Odor



# Replacement Parts & Accessories

Description	Part Number
<b>A</b> Replacement Element	3C-060/3C-090/3C-150
<b>B</b> Differential Pressure Indicator	N32-W1-DPI-FG
<b>B</b> Blanking Cap (Cover for Indicator)	N32-95-020-FG
<b>C</b> Bowl Assembly: Metal Bowl, Manual Petcock Drain, & O-ring (60)	N34-95-205-FG
<b>C</b> Bowl Assembly: Metal Bowl, Auto Float Drain, & O-ring (60)	N34-95-195-FG
<b>C</b> Bowl Assembly: Metal Bowl, Manual Petcock Drain, & O-ring (90/150)	N34-15-180-FG
<b>C</b> Bowl Assembly: Metal Bowl, Auto Float Drain, & O-ring (90/150)	N34-15-185-FG
<b>D</b> Manual Petcock Drain	PC-03
<b>E</b> Automatic Float Drain	N32-95-973-FG
<b>F</b> Bowl O-ring (60)	N32-95-257
<b>F</b> Bowl O-ring (90/150)	N32-95-256

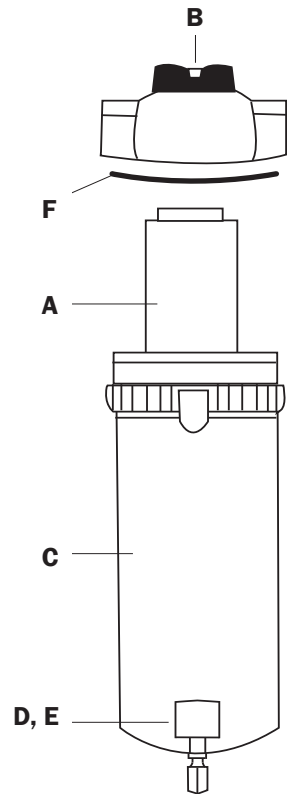

# Order Guide

	Port Size	Model Number	Dimensions (inches)		
			Height*	Width	Depth
<b>Manual Drain</b>	3/8"	3C-060-F03-P	10.0	3.9	3.9
	1/2"	3C-060-F04-P	10.0	3.9	3.9
	3/4"	3C-090-F06-P	17.0	4.6	4.8
	1"	3C-150-F08-P	17.0	4.6	4.8
<b>Automatic Plastic Float Drain</b>	3/8"	3C-060-F03-F	10.5	3.9	3.9
	1/2"	3C-060-F04-F	10.5	3.9	3.9
	3/4"	3C-090-F06-F	17.0	4.6	4.8
	1"	3C-150-F08-F	17.0	4.6	4.8

\*To add an indicator, add "i" to end of model number (Indicator adds about 1" to height)



(800) 521-9200

PDF available at [www.driair.com](http://www.driair.com)

# Specifications

<b>Port Sizes</b>	½”(60), 1” (90/150)
<b>Thread Styles</b>	NPT
<b>Flow Capacity</b>	60/90/150 scfm @ 100 PSI
<b>Filter Capacity</b>	1.0 micron & larger
<b>Differential Pressure</b>	< 3.0 PSID at rated flow
<b>Max Temp/ Pressure</b>	150 °F/250 PSIG
<b>Approx. Weight (lb.)</b>	7.0/10.0/10.0
<b>ISO Class</b>	2 Particulate

For higher pressure stainless steel applications, please consult factory.



NACE Compliant

**Water**  
**Dirt**  
**Oil**  
**Oil Vapor**  
**Odor**

# Replacement Parts & Accessories

Description	Part Number
<b>A</b> Replacement Element, 1st Stage	3P-060/3P-090/3P-150
<b>B</b> Manual Drain	SV1-3/8
<b>C</b> Automatic Float Drain	N32-95-973-FG
<b>D</b> Bowl O-ring (60)	KSG-171
<b>D</b> Bowl O-ring (90/150)	KSG-176
Mounting Bracket (Optional)	BK-1

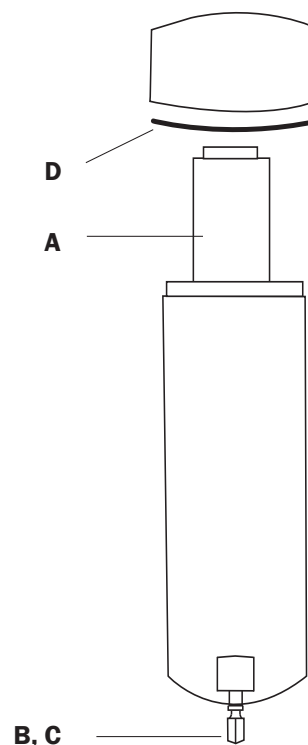

# Order Guide

	Port Size	Model Number	Dimensions (inches)		
			Height	Width	Depth
<b>Manual Drain</b>	½”	3P-060-S04-P	12.0	3.0	3.25
	1”	3P-090-S08-P	16.62	3.75	4.0
	1”	3P-150-S08-P	16.62	3.75	4.0
<b>Automatic Plastic Float Drain</b>	½”	3P-060-S04-F	11.0	3.0	3.25
	1”	3P-090-S08-F	15.62	3.75	4.0
	1”	3P-150-S08-F	15.62	3.75	4.0

# Specifications

<b>Port Sizes</b>	½" (60), 1" (90/150)
<b>Thread Styles</b>	NPT
<b>Flow Capacity</b>	60/90/150 scfm @ 100 PSI
<b>Filter Capacity</b>	0.01 micron & larger
<b>Differential Pressure</b>	< 3.0 PSID at rated flow
<b>Max Temp/ Pressure</b>	150 °F/250 PSIG
<b>Approx. Weight (lb.)</b>	14.0/20.0/20.0
<b>ISO Class</b>	1 Particulate/Oil

For higher pressure stainless steel applications, please consult factory.



NACE Compliant

**Water**  
**Dirt**  
**Oil**  
**Oil Vapor**  
**Odor**

# Replacement Parts & Accessories

Description	Part Number
<b>A</b> Replacement Element, 1st Stage	3P-060/3P-090/3P-150
<b>B</b> Replacement Element, 2nd Stage	3C-060/3C-090/3C-150
<b>C</b> Manual Drain	SV1-3/8
<b>D</b> Automatic Float Drain	N32-95-973-FG
<b>E</b> Bowl O-ring (60)	KSG-171
<b>E</b> Bowl O-ring (90/150)	KSG-176
Mounting Bracket (Optional)	BK-1

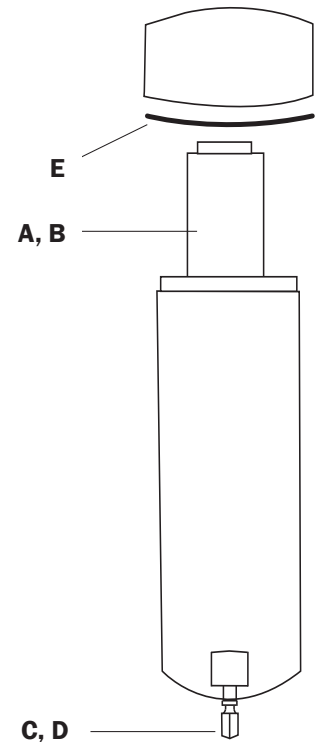

# Order Guide

	Port Size	Model Number	Dimensions (inches)		
			Height	Width	Depth
<b>Manual Drain</b>	½"	3P-060-S04-DCP	12.0	6.4	3.25
	1"	3P-090-S08-DCP	16.62	7.8	4.0
	1"	3P-150-S08-DCP	16.62	7.8	4.0
<b>Automatic Plastic Float Drain</b>	½"	3P-060-S04-DCF	11.0	6.4	3.25
	1"	3P-090-S08-DCF	15.62	7.8	4.0
	1	3P-150-S08-DCF	15.62	7.8	4.0



(800) 521-9200

PDF available at [www.driair.com](http://www.driair.com)

# Specifications

<b>Port Sizes</b>	½”(60), 1” (90/150)
<b>Thread Styles</b>	NPT, BSPT, BSPP
<b>Flow Capacity</b>	60/90/150 scfm @ 100 PSI
<b>Filter Capacity</b>	1.0 micron & larger (Single Stage) 0.01 micron & larger (Combo) Activated Carbon Oil Adsorption to 0.003 ppm < 3.0 PSID at rated flow
<b>Differential Pressure</b>	
<b>Max Temp/ Pressure</b>	150 °F/250 PSIG
<b>Manual Drain</b>	
<b>Max Temp/ Pressure</b>	125 °F/150 PSIG
<b>Auto Float Drain</b>	
<b>Approx. Weight (lb.)</b>	7.0/10.0/10.0 (Single Stage) 14.0/20.0/20.0 (Combo)
<b>ISO Class</b>	1 Particulate/Oil

For higher pressure stainless steel applications, please consult factory.



NACE Compliant

**Water**  
**Dirt**  
**Oil**  
**Oil Vapor**  
**Odor**

# Replacement Parts & Accessories

Description	Part Number
<b>A</b> Replacement Element, 1st Stage	4P-060/4P-090/4P-150
<b>B</b> Replacement Element, 2nd Stage (Combo Unit)	3C-060/3C-090/3C-150
<b>C</b> Manual Petcock Drain	SV1-3/8
<b>D</b> Automatic Float Drain	N32-95-973-FG
<b>E</b> Bowl O-ring (60)	KSG-171
<b>E</b> Bowl O-ring (90/150)	KSG-176
Mounting Bracket (Optional)	BK-1

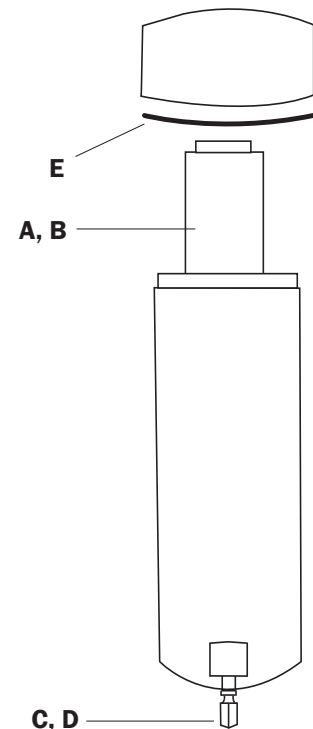

# Order Guide

	Port Size	Model Number	Dimensions (inches)		
			Height	Width	Depth
<b>Manual Drain</b>	½”	4P-060-S04-P	12.0	3.0	3.25
	1”	4P-150-S08-P	16.62	3.75	4.0
<b>Manual Drain COMBO</b>	½”	4P-060-S04-DCP	12	6.4	3.25
	1”	4P-090-S08-DCP	16.62	7.8	4.0
	1”	4P-150-S08-DCP	16.62	7.8	4.0
<b>Automatic Plastic Float Drain</b>	½”	4P-060-S04-F	11.0	3.0	3.25
	1”	4P-150-S08-F	15.62	3.75	4.0
<b>Automatic Plastic Float Drain COMBO</b>	½”	4P-060-S04-DCF	11.0	6.4	3.25
	1”	4P-090-S08-DCF	15.62	7.8	4.0
	1”	4P-150-S08-DCF	15.62	7.8	4.0

# Specifications

<b>Port Sizes</b>	½”(60), 1”(90/150/250)
<b>Thread Styles</b>	NPT, BSPT, BSPP
<b>Flow Capacity</b>	60/90/150/250 scfm @ 100 PSI
<b>Filter Capacity</b>	0.01 micron & larger
<b>Differential Pressure</b>	< 3.0 PSID at rated flow
<b>Max Temp/ Pressure</b>	
<b>Manual Drain</b>	150 °F/250 PSIG
<b>Max Temp/ Pressure</b>	
<b>Auto Float Drain</b>	125 °F/150 PSIG
<b>Approx. Weight (lb.)</b>	7.0/10.0/10.0/10.0
<b>ISO Class</b>	1 Particulate/Oil

For higher pressure stainless steel applications, please consult factory.



NACE Compliant

*Water  
Dirt  
Oil  
Oil Vapor  
Odor*

# Replacement Parts & Accessories

Description	Part Number
<b>A</b> Replacement Element	3C-060/3C-090/3C-150/3C-250
<b>B</b> Manual Petcock Drain	SV1-3/8
<b>C</b> Automatic Float Drain	N32-95-973-FG
<b>D</b> Bowl O-ring (60)	KSG-171
<b>D</b> Bowl O-ring (90/150/250)	KSG-176
Mounting Bracket (Optional)	BK-1

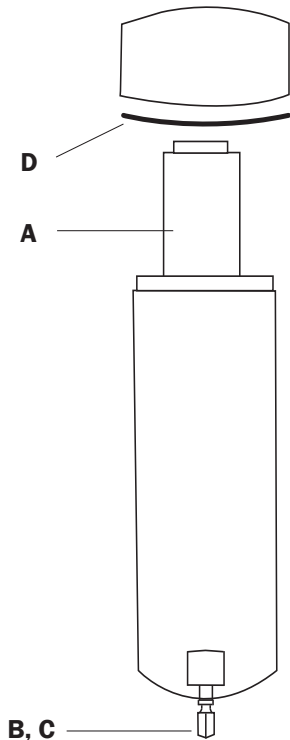

# Order Guide

	Port Size	Model Number	Dimensions (inches)		
			Height	Width	Depth
<b>Manual Drain</b>	½”	3C-060-S04-P	12.0	3.0	3.25
	1”	3C-090-S08-P	16.62	3.75	4.0
	1”	3C-150-S08-P	16.62	3.75	4.0
	1”	3C-250-S08-P	16.62	3.75	4.0
<b>Automatic Plastic Float Drain</b>	½”	3C-060-S04-F	11.0	3.0	3.25
	1”	3C-090-S08-F	15.62	3.75	4.0
	1”	3C-150-S08-F	15.62	3.75	4.0
	1”	3C-250-S08-F	15.62	3.75	4.0



(800) 521-9200

PDF available at [www.driair.com](http://www.driair.com)

# Specifications

<b>Port Sizes</b>	½", 1", 1 ½", 2", 3"
<b>Thread Styles</b>	NPT
<b>Material</b>	Aluminum
<b>Flow Capacity</b>	60/175/300/400/700/1200 scfm @ 100 PSI
<b>Filter Capacity</b>	3.0 micron & larger
<b>Differential Pressure</b>	< 1.0 PSID at rated flow
<b>Max Temp/ Pressure</b>	
<b>Metal HP Housing</b>	200° F/500 PSIG
<b>Max Pressure</b>	
<b>Automatic Float Drain</b>	250 PSIG
<b>Max Pressure</b>	
<b>Manual Drain</b>	500 PSIG
<b>Approx. Weight (lb.)</b>	3.5 - 40.0
<b>ISO Class</b>	3 Particulate



**Water**  
**Dirt**  
**Oil**  
**Oil Vapor**  
**Odor**

For higher pressure units, consult factory.

## Order Guide

### Manual Drain

Model Number	Port Size	Flow	Element Part Number	Manual Drain	O-ring	Dimensions (inches)		
						Height	Width	Depth
1P-060-M04-PHP	½"	60	1P-060	RTi-PC-002	KSG-005	10.0	3.1	3.0
1P-175-M08-PHP	1"	175	1P-175	RTi-PC-002	OR-235	15.4	4.6	3.7
1M-300-M12-PHP	1 ½"	300	1M-300	BV-051	PHC-036	33.0	6.0	5.7
1M-400-M16-PHP	2"	400	1M-400	BV-051	PHC-036	33.0	6.0	5.7
1M-700-M16-PHP	2"	700	1M-700	BV-051	PHC-036	33.0	8.0	5.7
1M-1200-M16-PHP	3"	1200	1M-1200	BV-051	PHC-032	40.0	8.0	7.3

### Automatic Float Drain

Model Number	Port Size	Flow	Element Part Number	Auto Drain	O-ring	Dimensions (inches)		
						Height	Width	Depth
1P-060-M04-FHP	½"	60	1P-060	AD-12	N32-95-257	10.0	3.1	3.0
1P-175-M08-FHP	1"	175	1P-175	AD-12	N32-95-235	15.4	4.6	3.7
1M-300-M12-FHP	1 ½"	300	1M-300	TD5	PHC-036	37.0	6.0	5.7
1M-400-M16-FHP	2"	400	1M-400	TD5	PHC-036	37.0	6.0	5.7
1M-700-M16-FHP	2"	700	1M-700	TD5	PHC-036	37.0	6.0	5.7
1M-1200-M24-FHP	3"	1200	1M-1200	TD5	PHC-032	44.0	8.0	7.3

# Specifications

<b>Port Sizes</b>	½", 1", 1 ½", 2", 3"
<b>Thread Styles</b>	NPT
<b>Flow Capacity</b>	60/150/300/400/700/1200 scfm @100 PSI
<b>Filter Capacity</b>	0.01 micron & larger
<b>Differential Pressure</b>	< 1.5 PSID at rated flow
<b>Max Temp/ Pressure</b>	
<b>Metal HP Housing</b>	200 °F/500 PSIG
<b>Max Pressure</b>	
<b>Automatic Float Drain</b>	250 PSIG
<b>Max Pressure</b>	
<b>Manual Drain</b>	500 PSIG
<b>Approx. Weight (lb.)</b>	3.5 - 40.0
<b>ISO Class</b>	1 Particulate/Oil



Water  
Dirt  
Oil  
Oil Vapor  
Odor

For higher pressure units, consult factory.

## Order Guide

### Manual Drain

Model Number	Port Size	Flow	Element Part Number	Manual Drain	O-ring
3C-060-M04-PHP	½"	60	3C-060	RTi-PC-002	KSG-005
3C-150-M08-PHP	1"	150	3C-150	RTi-PC-002	OR-235
3C-300-M12-PHP	1 ½"	300	3C-300	BV-051	PHC-036
3C-400-M16-PHP	2"	400	3C-400	BV-051	PHC-036
3C-700-M16-PHP	2"	700	3C-700	BV-051	PHC-036
3C-1200-M24-PHP	3"	1200	3C-1200	BV-051	PHC-032

Dimensions (inches)		
Height	Width	Depth
10.0	3.1	3.0
15.4	4.6	3.7
33.0	6.0	5.7
33.0	6.0	5.7
33.0	8.0	5.7
40.0	8.0	7.3

### Automatic Float Drain

Model Number	Port Size	Flow	Element Part Number	Auto Drain	O-ring
3C-060-M04-FHP	½"	60	3C-060	AD-12	N32-95-257
3C-150-M08-FHP	1"	150	3C-150	AD-12	PHC-035
3C-300-M12-FHP	1 ½"	300	3C-300	TD5	PHC-036
3C-400-M16-FHP	2"	400	3C-400	TD5	PHC-036
3C-700-M16-FHP	2"	700	3C-700	TD5	PHC-036
3C-1200-M24-FHP	3"	1200	3C-1200	TD5	PHC-032

Dimensions (inches)		
Height	Width	Depth
10.0	3.1	3.0
15.4	4.6	3.7
37.0	6.0	5.7
37.0	6.0	5.7
37.0	6.0	5.7
44.0	8.0	7.3



(800) 521-9200

PDF available at [www.driair.com](http://www.driair.com)

## Features & Benefits

- Unique, energy efficient cycling dryer reduces costs up to 80%
- Compact size for easy fit
- Automatic timer drain (with manual override)
- No gas expansion valve = no freezing up
- Low maintenance, long life design
- On/Off switch with multi-function display



## Specifications

- 20-2000 scfm, depending on model
- Port sizes: ¼" - 4"
- Maximum work: 230 PSIG
- Maximum temperature: 158 °F
- Maintains constant dew point: 38 °F

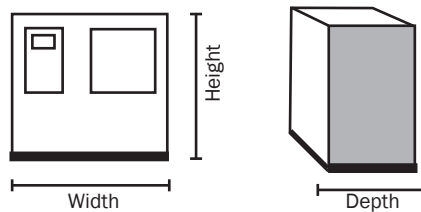

## Order Guide

Model Number	Air Flow (scfm)	Air Connection (NPT)	Net Weight (lb)	Height (in)	Width (in)	Depth (in)
RD 0020	20	½"	80	20.10	20.90	11.80
RD 0030	30	½"	86	20.10	20.90	11.80
RD 0050	50	½"	91	20.10	20.90	11.80
RD 0075	75	¾"	143	29.50	25.60	14.60
RD 0100	100	¾"	148	29.50	25.60	14.60
RD 0125	125	1"	176	29.50	25.60	14.60
RD 0150	150	1"	209	33.50	30.70	14.60
RD 0175	175	1"	227	33.50	30.70	14.60
RD 0200	200	1½"	368	37.00	30.70	28.90
RD 0250	250	1½"	368	37.00	30.70	28.90
RD 0325	325	1½"	416	37.00	30.70	28.90
RD 0425	425	2"	582	43.30	34.00	40.00
RD 0520	520	2"	646	43.30	34.00	40.00
RD 0600	600	2½"	833	43.30	34.00	51.90
RD 0700	700	2½"	866	43.30	34.00	51.90
RD 0800	700	2½"	866	43.30	34.00	51.90
RD 1000	1000	3"	1598	61.70	37.90	62.60
RD 1200	1220	4"	1907	61.70	37.90	71.30
RD 1600	1600	4"	2513	81.70	34.10	88.00
RD 2000	2000	4"	3064	81.70	34.10	88.00

Call factory for various power supply options for each model as well as information on non-cycling models.



# Specifications

<b>Port Sizes</b>	1/4", 3/8", 1/2"
<b>Thread Styles</b>	NPT, BSPT, BSPP
<b>Flow Capacity</b>	25 scfm @ 100 PSI
<b>Filter Capacity</b>	1.0 Micron & larger (Activated Carbon Oil Absorption to 0.003 ppm)
<b>Differential Pressure</b>	< 5.0 PSID at rated flow
<b>Max Temp/ Pressure</b>	
<b>Aluminum Bowl</b>	125 °F/150 PSIG
<b>Approx. Weight (lb.)</b>	14.0
<b>ISO Class</b>	2 Particulate/Oil & 2 Pressure Dew Point



**Water**  
**Dirt**  
**Oil**  
**Oil Vapor**  
**Water Vapor**  
**Odor**

# Replacement Parts & Accessories

Description	Part Number
<b>A</b> Replacement Element, 1st Stage	4P-060
<b>B</b> Replacement Element, 2nd Stage	DE401
<b>C</b> Differential Pressure Indicator	N32-W1-DPI
<b>C</b> Blanking Cap (Cover for Indicator)	N32-95-020
<b>D</b> Bowl Assembly: 1st Stage (Bowl, Drain, O-ring)	N34-95-201
<b>E</b> Bowl Assembly: 2nd Stage (Bowl, Drain, O-ring)	N34-15-180
<b>F</b> O-ring: 1st Stage	N32-95-257
<b>G</b> O-ring: 2nd Stage	N32-95-256
<b>H</b> Automatic Float Drain: 1st Stage	N32-95-979
<b>J</b> Pressure Gauge	PG-160
<b>K</b> Regulator, 1/4"	R79
<b>L</b> Sight Glass	RTI-SG-651
<b>M</b> Petcock Drain	PC-03

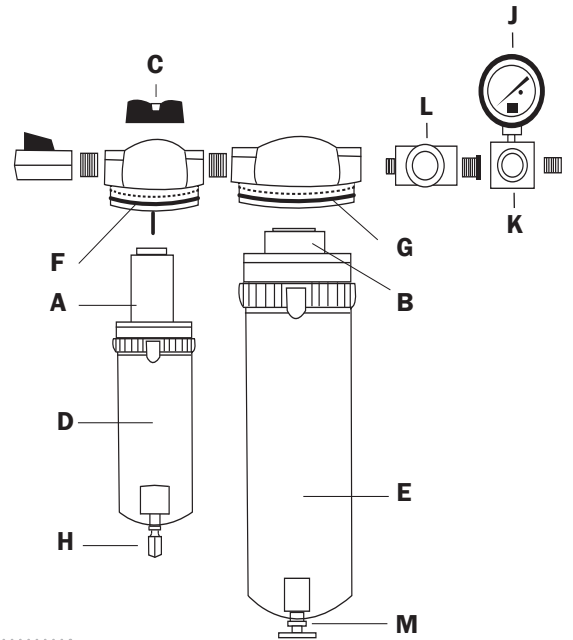

# Order Guide

	Port Size	Model Number	Dimensions (inches)		
			Height	Width	Depth
1/4" Regulator & Gauge Assembly	1/4"	E4000-2	19.0	17.0	5.4
	3/8"	E4000-3	19.0	17.0	5.4
	1/2"	E4000-4	19.0	17.0	5.4
No Regulator & Gauge Assembly	1/4"	N4000-2	19.0	14.0	5.4
	3/8"	N4000-3	19.0	14.0	5.4
	1/2"	N4000-4	19.0	14.0	5.4



(800) 521-9200

PDF available at [www.driair.com](http://www.driair.com)

# Specifications

<b>Port Sizes</b>	1/4" - 1/2"
<b>Thread Styles</b>	NPT
<b>Flow Capacity</b>	25 scfm @ 100 PSI
<b>Filter Capacity</b>	1.0 Micron & larger
<b>Differential Pressure</b>	<5.0 PSID at rated flow
<b>Max Temp/ Pressure Aluminum Bowl</b>	175 °F/200 PSIG
<b>Max Temp/ Pressure Polycarbonate Bowl</b>	125 °F/150 PSIG
<b>Approx. Weight (lb.)</b>	5.0-8.0
<b>ISO Class</b>	2 Particulate/Oil & Class 2 Pressure Dew Point



**Water**  
**Dirt**  
 Oil  
 Oil Vapor  
**Water Vapor**  
 Odor

# Replacement Parts & Accessories

Description	Part Number
<b>A</b> Replacement Element, 1st stage	DE301/DE350/DE401
<b>B</b> O-ring: for DE350-P02/P04 & DE301-M04	N32-95-256
<b>B</b> O-ring: for DE401-M04	N32-95-257
<b>C</b> Bowl Assembly: for DE301-M04 (Bowl, Drain, O-ring)	N34-95-201
<b>C</b> Bowl Assembly: for DE350-P02/P04 (Bowl, Drain, O-ring)*	N32-15-167
<b>C</b> Bowl Assembly: for DE401-M04 (Bowl, Drain, O-ring)	N34-15-180
<b>D</b> Manual Brass Petcock Drain:for DE350-P02/P04	N32-95-182
<b>D</b> Petcock Drain: for DE301-M04	PC-02
<b>D</b> Petcock Drain: for DE401-M04	PC-03
Sight Glass Assy: for DE401-M04	RTi-SG-651

\*Poly bowls come with metal bowl guard

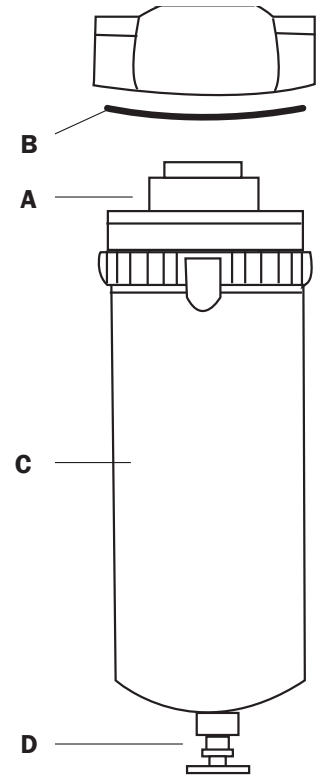

# Order Guide

Model Number	Port Size	Bowl Type	Flow Capacity	Dimensions (inches)		
				Height	Width	Depth
DE350-P02	1/4"	Poly	10scfm	13.6	5.2	4.8
DE350-P04	1/2"	Poly	10 scfm	13.6	4.6	4.8
DE301-M04	1/2"	Metal	8 scfm	9.9	3.9	3.9
DE401-M04	1/2"	Metal	10 scfm	16.5	6.8	4.8



# Specifications

<b>Port Sizes</b>	¾", 1"
<b>Thread Styles</b>	NPT, BSPT, BSPP
<b>Flow Capacity</b>	25 scfm @ 100 PSI
<b>Filter Capacity</b>	1.0 Micron & larger Activated Carbon Oil Adsorption to 0.003 ppm < 5.0 PSID at rated flow
<b>Differential Pressure</b>	
<b>Max Temp/ Pressure</b>	125 °F/150 PSIG
<b>Aluminum Bowl</b>	25.0
<b>Approx. Weight (lb.)</b>	1 Particulate/Oil & 2 Pressure Dew Point
<b>ISO Class</b>	



**Water**  
**Dirt**  
**Oil**  
**Oil Vapor**  
**Water Vapor**  
**Odor**

# Replacement Parts & Accessories

Description	Part Number
<b>A</b> Replacement Element, 1st Stage	4P-090 (for E6000) 4P-150 (for E8000)
<b>B</b> Replacement Element, 2nd & 3rd Stage	DE6000
<b>C</b> Differential Pressure Indicator	N32-W1-DPI
<b>C</b> Blanking Cap (Cover for Indicator)	N32-95-020
<b>D</b> Assembly: 1st Stage (Bowl, Drain, O-ring)	N34-15-178
<b>E</b> Assembly: 2nd & 3rd Stage (Bowl, Drain, O-ring)	N34-15-180
<b>F</b> O-ring	N32-95-256
<b>G</b> Automatic Float Drain: 1st Stage	N32-95-979
<b>H</b> Manual Brass Drain: 2nd Stage & 3rd Stage	PC-03
<b>I</b> Replacement Regulator, ¾" (E6000)	NAR5000-N06
<b>J</b> Replacement Regulator, 1" (E8000)	NAR5000-N10
<b>K</b> Replacement Gauge	KSG-008

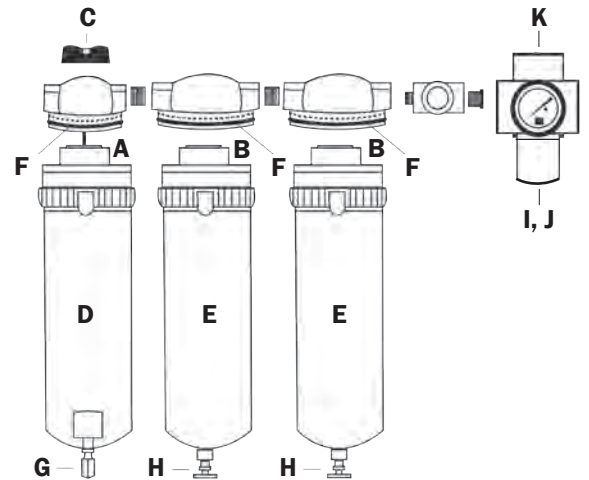

# Order Guide

Model Number	Port Size	Dimensions (inches)		
		Height	Width	Depth
E6000	¾"	18.0	30.0	5.0
E8000	1"	18.0	30.0	5.0



## Specifications

For All DRAD units

- Requires 110 volt service
- Max inlet pressure 100 PSI on units up to 30 scfm, 150 PSI on larger dryers
- 1.0 to 0.01 micron filtration capacity
- 100 °F Inlet air temperature

### DRAD 4 to 30

- Compact Design
- (2) moving parts
- -40°F, -100°F dewpoints
- Flow rates from 4-30 scfm
- ISO Class 1 Dewpoint
- Complete packages which include: dryer, (2) stage pre-filter & after-filter



### DRAD 80 to 250

- Pilot Air Filter
- Separate drain & fill port
- Tower pressure gauge
- ASME code construction & stamped pressure vessels (6" diameter and larger)
- Front mounted control panel
- NEMA 4 Electrical enclosure on units over 30 scfm
- On/Off Switch
- Pre-piped & mounted pre-filter & after-filter
- Purge exhaust piston valve
- Non-lubricated inlet valve
- Structural Steel frame with floor stand
- Full charge of desiccant
- Safety pressure relief valve for each tank
- Fail safe design against power failure: bi-directional piston valve remains in the same position to ensure air-flow throughout dryer without interruption
- Field adjustable timer cycle: 4, 10, or 15 minutes
- High efficiency angle body piston purge valve
- Springload check valves
- Stainless steel inlet/outlet diffusers
- -40°F, -100°F dewpoints
- 250 PSI
- Filters mounted



## Order Guide

Model Number	Air Flow (scfm)	Air Connection (NPT)	Net Weight (lb)	Height (in)	Width (in)	Depth (in)
DRAD-4	4	1/4	25	20.5	9.5	4.6
DRAD-8	8	1/4	30	27.5	9.75	4.6
DRAD-15	15	3/8	45	45.0	9.75	4.6
DRAD-25	25	3/8	65	51.0	10.5	4.6
DRAD-30	30	3/8	72	58.0	10.5	4.6
DRAD-80	80	3/4	550	76.0	24.0	34.0
DRAD-100	100	1	690	76.0	24.0	34.0
DRAD-150	150	1	710	76.0	36.0	40.0
DRAD-250	250	1 1/2	1010	83.0	40.0	44.0

A prefilter and after-filter are recommended. Larger sizes available. Contact the factory for more info.

## Filters & Filter/Regulators

- Light weight acetal body with polyamide bowl
- Filter/Regulator with glass face chrome gauge
- Low pressure drop
- Semi-automatic drain with manual override
- Filter with adjustable 0-120 PSI regulator
- Can be wall mounted or panel nut mounted



## Lubricators

- Light weight acetal body with polyamide bowl
- Siphon tube filter provides clean lubricant downstream
- Adjustable oil feed with tamper-proofing capability
- Can be filled while under pressure



## Order Guide

Filter	Model Number*	Port Size (in)	Flow Capacity (scfm)	Maximum Supply Pressure (PSIG)	Maximum Operating Temp (°F)	Filter Capacity	Dimensions Height x Width x Depth (in)
	RT-F250	¼"	30	230	120	5 micron	5.75 x 1.65 x 1.65
RT-F380	⅜"	80	230	120	5 micron	6.85 x 2.49 x 2.05	
RT-F500	½"	80	230	120	5 micron	8.03 x 2.95 x 2.49	
Filter/ Regulator	RT-FR250-G	¼"	30	230	120	5 micron	7.80 x 1.65 x 1.65
	RT-FR380-G	⅜"	80	230	120	5 micron	9.41 x 2.49 x 2.05
	RT-FR500-G	½"	80	230	120	5 micron	10.87 x 2.95 x 2.49

Lubricator	Model Number	Port Size (in)	Flow Capacity (scfm)	Maximum Supply Pressure (PSIG)	Maximum Operating Temp (°F)	Supply Capacity (cc)	Dimensions Height x Width x Depth (in)
	L250	¼"	30	230	120	42	6.18 x 1.65 x 1.65
L380	⅜"	80	230	120	68	7.95 x 2.05 x 2.49	
L500	½"	80	230	120	140	8.94 x 2.49 x 2.95	

\* To order Filter/Regulator without gauge, substitute "-O" for "-G" in model number.

## Accessories & Replacement Parts

Filter	Part Number	Replacement Element	Replacement Gauge	Bowl Assy	O-Ring	Mounting Bracket (Optional)
	RT-F250	F250-E	--	F250-BMD	F250-OR	F250-BKT
RT-F380	F380-E	--	F380-BMD	F380-OR	F380-BKT	
RT-F500	F500-E	--	F500-BMD	F500-OR	F500-BKT	
Filter/ Regulator	RT-FR250-G	FR250-E	PG-160-1.5CB	F250-BMD	F250-OR	F250-BKT
	RT-FR380-G	FR380-E	PG-160-1.5CB	F380-BMD	F380-OR	F380-BKT
	RT-FR500-G	FR500-E	PG-160-1.5CB	F500-BMD	F500-OR	F500-BKT



(800) 521-9200

PDF available at [www.driair.com](http://www.driair.com)

## Regulators & Gauges

- Light weight non-corrosive construction
- All Stainless Steel inserts on MR Series Regulators
- Panel nut included
- Excellent reliability



Non-Corrosive  
Acetal Resin



316 Stainless  
Steel



Brass

Model Number (for unit with gauge+)	Material	Flow Capacity (scfm)	Adjusting Range Pressure (PSIG)	Port Size (NPT)	Maximum Supply Pressure (PSIG)	Maximum Operating Temp (°F)	Dimensions (inches) Diameter (B) x Height (A)
R250SSMINI6-G++	316 Stainless Steel/Acetal	18	5-60	1/4"+++	250	200	1.44 x 2.75
R250BRMINI6-G	Brass/Acetal	18	5-60	1/4"+++	250	175	1.44 x 2.75
R250SSMINI-G++	316 Stainless Steel/Acetal	18	10-130	1/4"+++	250	200	1.44 x 2.75
R250BRMINI-G	Brass/Acetal	18	10-130	1/4"+++	250	175	1.44 x 2.75
MR0030-01G	Acetal Resin	30	0-30	1/8"	230	125	1.6 x 3.0
MR0060-01G	Acetal Resin	30	0-60	1/8"	230	125	1.6 x 3.0
MR0120-01G	Acetal Resin	30	0-120	1/8"	230	125	1.6 x 3.0
MR1030-02G	Acetal Resin	30	0-30	1/4"	230	125	1.6 x 3.0
MR1060-02G	Acetal Resin	30	0-60	1/4"	230	125	1.6 x 3.0
MR1120-02G	Acetal Resin	30	0-120	1/4"	230	125	1.6 x 3.0

+ To order without gauge, omit '-G' from the model number.

++ Stainless Steel Unit, NACE Compliant MR0175 STD, Low pressure drop, fluorocarbon diaphragm/seals.

+++ Also available in 1/8" NPT ports & non-relieving types. Call factory for options.

## Replacement Gauges



**PG-160**

2" Diameter Gauge,  
0-160 PSI  
1/8" Bottom Mount  
(E4000 Dryers)



**PG-030-15C**

1.5" Diameter Gauge,  
0-30 PSI  
1/8" Centered Back  
(MR Series)



**PG-060-1.5-CB**

1.5" Diameter Gauge,  
0-60 PSI  
1/8" Centered Back  
(MR Series)



**PG-160-1.5-CB**

1.5" Diameter Gauge,  
0-160 PSI  
1/8" Centered Back  
(MR & FR Piggyback Series)



**KSG-008**

2" Diameter Gauge,  
0-160 PSI  
1/4" Centered Back  
(HD Regulator Series)

## Heavy Duty: Regulators

- Rugged, heavy duty high-flow design
- All metal, corrosion-resistant anodized aluminum body
- Tee handle knob, relieving type regulator
- Chemically resistant Buna N diaphragm
- Gauge included with units (also available without gauge)
- Lockout valves available
- 1/4", 3/8", 1/2", 3/4", 1", 1 1/4", 1 1/2" NPT ports available
- Higher pressure units available--call factory.

Model Number (for unit with gauge+)	Flow Capacity (scfm)	Adjusting Range Pressure (PSIG)	Port Size (NPT)	Maximum Supply Pressure (PSIG)	Maximum Operating Temp (°F)	Weight (lbs)	Dimensions (inches) Diameter x Height
R250HD-G	86	10-130	1/4"	250	175	1.2	2.25 x 4.58
R380HD-G	100	10-130	3/8"	250	175	1.2	2.25 x 4.58
R500HD-G	108	10-130	1/2"	250	175	1.2	2.25 x 4.58
R500HD-SS-G ++	108	10-130	1/2"	250	200	1.2	2.25 x 4.58
R750HD-G	175	10-130	3/4"	250	175	3.2	3.75 x 6.75
R1000HD-G	300	10-130	1"	250	175	3.2	3.75 x 6.75
R1250HD-G	450	10-130	1 1/4"	250	175	3.9	4.0 x 6.75
R1500HD-G	450	10-130	1 1/2"	250	175	3.9	4.0 x 6.75

Inlet pressure 100 PSIG (6.9 bar). Secondary pressure 80 PSIG (5.5 bar).

+ To order without gauge, omit '-G' from the model number.

++ Stainless Steel Unit, NACE Compliant MR0175 STD, Low pressure drop, fluorocarbon diaphragm/seals.

### R250HD & R500HD

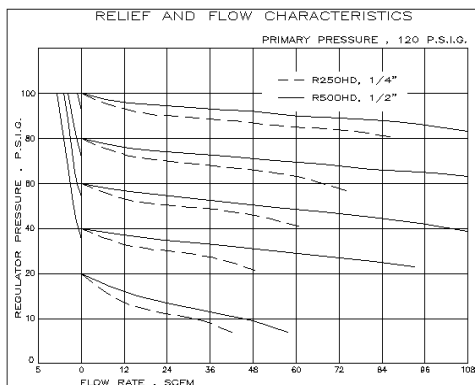

316 Stainless Steel



Anodized Aluminum

### R750HD & R1000HD

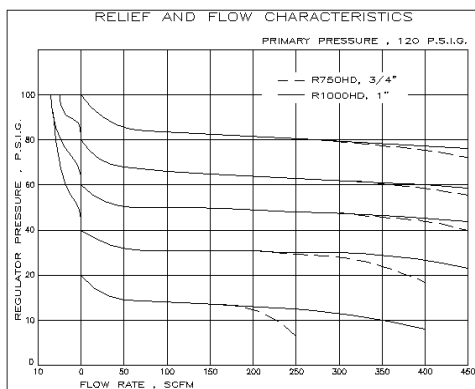

### R1250HD & R1500HD

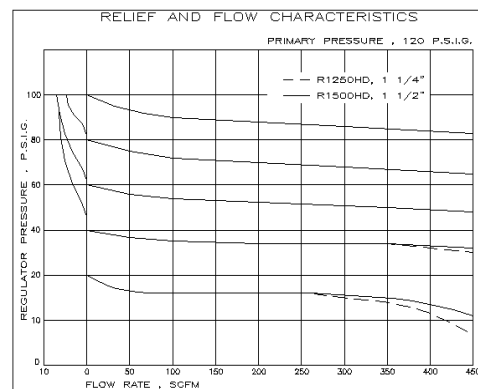

(800) 521-9200

PDF available at [www.driair.com](http://www.driair.com)

## Filters



- Filters to 3 micron
- Anodized Aluminum housing with manual or auto drain
- Threaded bowl for ¼” to ½” sizes
- Optional Sight Glass available
- Economic & Durable

Model Number with auto drain*	Flow (scfm)	Maximum Supply Pressure (PSIG)	Port Size (NPT)	Maximum Operating Temp (°F)	Weight (lbs)	Dimensions (inches) Diameter x Height
F250HDMF	30	250	¼”	200	3.0	2.50 x 6.50
F380HDMF	75	250	⅜”	200	3.0	2.50 x 6.50
F500HDMF	85	250	½”	200	3.0	2.50 x 6.50
F750HDMF	175	250	¾”	200	4.0	3.75 x 8.00
F1000HDMF	240	250	1”	200	4.0	3.75 x 8.00
F1250HDMF	320	250	1 ¼”	200	4.5	4.00 x 10.50
F1500HDMF	400	250	1 ½”	200	4.5	4.00 x 10.50

\*For model with manual drain, replace “F” with “P”. For model with optional sight glass, add “T” to end of model number.

## Lubricators



- Rugged, heavy duty high-flow design
- Anodized Aluminum housing
- Siphon tube filter provides clean lubricant downstream
- Twist-off easy bowl removal
- Adjustable oil feed w/ tamper-proofing capability
- Can be filled while under pressure
- ¼” through 1 ½” NPT ports available

Model Number	Flow	Maximum Supply Pressure (PSIG)	Port Size (NPT)	Maximum Operating Temp (°F)	Weight (lbs)	Dimensions (inches) Diameter x Height
L250HDM	40	250	¼”	200	3.0	2.50 x 6.88
L380HDM	100	250	⅜”	200	3.0	2.50 x 6.88
L500HDM	120	250	½”	200	3.0	2.50 x 6.88
L750HDM	190	250	¾”	200	4.0	3.75 x 11.25
L1000HDM	270	250	1”	200	4.0	3.75 x 11.25
L1250HDM	600	250	1 ¼”	200	4.5	4.00 x 11.62
L1500HDM	750	250	1 ½”	200	4.5	4.00 x 11.62



## Rotary Screw 5-100 HP

Units employ 100% duty cycle, eliminating overwork of the compressor.

Simple maintenance and once-a-year oil change make this series a perfect fit for body shops and many other applications.

- Available 5-100 HP
- Operating pressures from 100-180 PSI
- Low speed rotors on air end for long life
- Less than 3 ppm oil carry over
- (1) solenoid valve operates machine
- Quiet operation
- Spin on separator & oil filter
- Oil after-cooler on all models
- 8000 hour full synthetic oil standard
- 125, 150, 175 operating pressure at no extra charge
- Analog controls-- No unnecessary/unreliable microprocessor
- 5 year extended warranty available for air end
- German air end components

Model Number	HP	Vert /Horiz	ACFM at 125 PSI	ACFM at 150 PSI	Tank Size	Air End	Voltage Info	Amps at 230 Volt
RSH-835-19-B	5	H	19	18	80	NK31	208-230/480/3	16
RSH-837.5-29-B	7.5	H	29	26	80	NK31	208-230/480/3	18
RSH-8310-42-B	10	H	42	40	80	NK31	208-230/480/3	28
RSH-12315-68-B	15	H	68	55	120	NK62	208-230/480/3	42

Single phase, vertical, and enclosed configurations available. Please contact factory for full product line.



Screw



Piston

## Piston 5-15 HP

The Industrial Series compressors are designed for heavy duty automotive and industrial applications.

CA2 pumps are manufactured for durability and run at low RPM to provide reliable air for your application.

- Solid cast-iron pump
- Disc and spring valves
- Centrifugal unloader
- Low pump rpm
- Oil sight glass
- Oil drain and fill on front of compressor pump
- Heavy duty NEMA motors
- OSHA style totally enclosed belt guard
- ASME code receivers
- Needle bearings

Model Number	HP	Vert /Horiz	ACFM at 125 PSI	ACFM at 175 PSI	Tank Size	Voltage Info	Amps at 230 Volt
PV-815-19-B	5	V	19.0	17.5	80	208-230/1	24
PV-837.5-32-B	7.5	V	32.1	28.0	80	208-230/480/3	18
PH-837.5-32-B	7.5	H	32.1	28.0	80	208-230/480/3	18
PV-8310-37-B	10	V	36.9	35.4	80	208-230/480/3	28
PH-8310-37-B	10	H	36.9	35.4	80	208-230/480/3	28

Single phase, vertical, and enclosed configurations available. Please contact factory for full product line.



(800) 521-9200

PDF available at [www.driair.com](http://www.driair.com)



**BRAD-BD1**

**includes:**

Prefilter, Final Filter, CO Monitor, Heavy Duty Regulator with 0-160 PSI Gauge, MR-1 Mini Regulator

**BRAD-CM3**  
CO Monitor



- Monitors Grade “D” Breathable Air
- Ultra lightweight design
- Activated carbon pre-filter for hydrocarbon removal to 0.003 ppm
- 0.01 micron final filter—fine particulate & oil removal at 99.9998%
- Dual ½” outlets with ¼” high flow, quick disconnects provided
- Rated for up to 60 scfm
- Heavy duty, high flow regulator assembled with FDA lubricant
- 0-60 PSIG mini-regulator controls air pressure to monitor
- Low purge loss through monitor
- 110 Volt AC Electrical
- 1-2 operators
- Easy Install: Assembly is mounted on a ¾” board

## Parts & Accessories

Description	Part Number
<b>A</b> Full Face Mask Assy. with Flow Control Valve	BRAD-M1C
<b>B</b> Flip Up Mask Assy. with Flow Control Valve	BRAD-M2C
<b>C</b> Disposable Hood Assy. with Flow Control Valve	BRAD-M3C
<b>D</b> Peel Off Lens (25 pack for BRAD-M1C)	BRAD-M1-LC
<b>E</b> Peel Off Lens (10 pack for BRAD-M2C)	BRAD-M2-LC
<b>F</b> Peel off Lens (10 pack for BRAD-M3C)	BRAD-M3-LC
<b>G</b> Breathing Hose, 35'	HVHA-B35C
<b>H</b> Breathing Hose, 50'	HVHA-B50C
<b>I</b> Humidifer	BRAD-HD1
<b>J</b> Vortex Cooler	BRAD-VC
<b>K</b> Heavy Duty Regulator, ½”	R500HD
<b>L</b> Gauge, 0-160 PSIG (for R500HD)	PG-160
<b>M</b> Mini Regulator	MR1060-020
<b>N</b> Gauge, 0-160 PSIG (for MR1060-020)	PG-060-1.5-CB
Replacement Hood	BRAD-M3-RH
1 Year Element Kit	BRAD-01C-MK
Includes: (2) 3C-061, (4) 4P-060	



3 mask styles available with operator kits. Contact factory for options.



Standard Automatic Replacement Drains



**N32-95-973**  
Auto Float,  
Plastic  
3/8" Tube Outlet



**N32-95-978**  
Auto Float,  
Brass with  
Manual Override  
1/8"NPT Outlet



**N32-95-979**  
Auto Float,  
Composite/Plastic  
1/4" NPT Outlet



**N32-95-XD8**  
Auto Float,  
External Bowl  
1/2" NPT Inlet  
3/4" NPT Outlet

Standard Manual Replacement Drains



**PC-02**  
1/4" Petcock  
Brass



**PC-03**  
3/8" Petcock  
Brass



**BV-051**  
1/2" Ball Valve with  
Handle

Additional Drip Leg & Receiver Tank Drains



**ED-24**  
Electronic Timer Drain  
110 Volts AC  
-Adjustable discharge  
-Span & Interval with  
Manual Override  
-Includes Brass Strainer  
with shut-off valve for  
easy maintenance



**TD-5**  
Tank Drain  
Combination  
Automatic Float  
& Manual Petcock  
Drain



**MAG 11**  
Magnetic  
Zero Air Loss Drain  
-up to 250 gallon tank  
- use in conjunction with  
JBVY-500-M  
(Magnetic Y-Strainer  
with valve)



**RTI-POD-DC**  
Automatic  
Zero Air Loss Drain  
up to 3500 scfm



**3P-150-M08-FiST**  
Unit with Stand:  
Eliminizer, 150 scfm\*  
1" NPT with Stand



**3P-060-M04-FRLST**  
FRL Unit with Stand:  
Eliminizer, 60 scfm\*  
1/2" NPT with Stand



**EH-STAND**  
Stand Only:  
Eliminator II  
Demo Unit



**3P-150-M08-DCST**  
Combo Unit with Stand:  
Eliminizer Combo, 150 scfm\*  
1" NPT with Stand



**1M-700-M16-PST (700 scfm)**  
**1M-1200-M24-PST (1200 scfm)**

Unit with Stand:  
Portable Elimex Filter with  
Heavy Duty Stand  
Shown with  
optional MAG11 drain



**RT-FMR-1**

Display Kit, 12"x18"  
1/4" & 1/2" Filter-Regulator  
and Mini Regulator  
Comes with mounting hardware

The **RT-FMR-1** is the perfect visual for our filter-regulators. Efficient sales tool with informational text & order info on a heavy duty laminate poster for mounting to peg board. Comes with product images printed on the board should you sell your display model—convenient while waiting for replacement stock.

**Features:**

- RT-FR250-G**
- RT-FR500-G**
- MR1120-02G**

\* Consult factory for additional filter units available with stand.



## Mounting Brackets



**GPA-95-016**  
20 scfm only  
Wall Mounted



Example  
3P-020-M02-Fi  
mounted with  
GPA-95-016



**N34-95-969**  
20 scfm only  
(Can be used to connect  
combo unit modularly)



Example  
3P-020-M02-Fi  
mounted with  
N34-95-969



**BK-1**  
60 SCFM Only  
Wall Mounted  
(Combo units require two)



**PB-004**  
½" Models Only  
Supports units on pipe  
(Units can still rotate)



**N32-95-734**  
Universal  
¼" - 1" Units  
¼" x ½" slots  
on 1½" centers

## Differential Pressure Indicator



**N32-W1-DPI**  
Differential pressure indicator  
(used on most models ¼" - 2" NPT)



**N32-95-020**  
Blanking cap  
(To replace indicator)

## High Flow Couplers & Plugs

Easy Assembly/Disassembly • High Quality Brass Construction • High Pressure Applications • ¼ NPT Male or Female Connections



**HFFC-1**



**HFFP-1**



**HFMC-1**



**HFMP-1**

Compatible with  
our PH35C  
Conductive hoses.  
Consult factory



**For Eliminex® Units**

1P-060	60 SCFM
1P-090	90 SCFM
1P-120	120 SCFM
1P-150	150 SCFM
1P-175	175 SCFM
1M-300	300 SCFM
1M-400	400 SCFM
1M-700	700 SCFM
1M-1200	1200 SCFM
1M-2500	2500 SCFM
1M-5500	5500 SCFM



**1P  
&  
1M**

**3.0 Micron  
& Larger**

*Media:  
Washable Stainless Steel Mesh*

**For Coalescing Units**

3C-020	20 SCFM
3C-021*	20 SCFM
3C-060	60 SCFM
3C-061*	60 SCFM
3C-090	90 SCFM
3C-091*	90 SCFM
3C-150	150 SCFM
3C-151*	150 SCFM
3C-250	250 SCFM
3C-251*	250 SCFM
3C-300	300 SCFM
3C-301*	300 SCFM
3C-400	400 SCFM
3C-401*	400 SCFM
3C-700	700 SCFM
3C-701*	700 SCFM
3C-1200	1200 SCFM
3C-1201*	1200 SCFM
3C-1900	1900 SCFM
3C-3000	3000 SCFM



**3C**

**0.01 Micron  
& Larger**

*Media:  
Long lasting borosilicate material  
\*Grade 1: A finer grade coalescing element  
with a rating of 0.01 micron at 99.99998%  
Grade 2 is standard*

*Elements are shown clear for demonstration only.*

**For Eliminer® Units**

3P-020	20 SCFM
3P-035	35 SCFM
3P-060	60 SCFM
3P-090	90 SCFM
3P-150	150 SCFM



**3P**

**1.0 Micron  
& Larger**

*Media:  
Stainless Steel  
Mesh &  
Woven Cotton/  
Polyester Blend*

**For Oil-Extractor® Units**

4P-060	60 SCFM
4P-090	90 SCFM
4P-150	150 SCFM



**4P**

**1.0 Micron  
& Larger**

*Media:  
Stainless Steel  
Mesh,  
Woven Cotton  
& Activated Carbon*

Combo units have 2 replacement elements:  
1st stage element

(The first 5 characters in the model number)  
with a coordinating

2nd stage coalescing element

**3P-060-M04-DCi**



3P-060 + 3C-060



# RTi-QAT Kit: Quality Air Tester

**In just a few minutes, you could save thousands of dollars by identifying the 3 major causes of refinish problems:**

- Inadequate compressed air supply
- Compressed air humidity
- Particulate contamination

**Accurately test the quality of the air in compressed air lines, filters, hoses and related equipment. Clean dry air, free from humidity, oil, and particulate contamination is essential for many professional applications.**

**Our kit checks critical aspects of your paint air, at the point of use & throughout the entire facility:**

- Static air pressure
- Dynamic air pressure
- Air Dew Point
- Air Contamination
- Air Temperature
- Relative Humidity



**RTi-QAT**

## Excellent Sales Tool

Requires some initial training for use (recommended)

## Excellent Maintenance Tool

### Kit contains:

- Contaminant Checker  
Sampler vessel with contaminant capturing membrane disc, & magnifying lens with integral light source
- RH Humidity Checker, 0-100% Range  
Measures compressed air temperature & dew point.  
(Paint MFR's now specify 10% RH or lower)



(800) 521-9200

PDF available at [www.driair.com](http://www.driair.com)

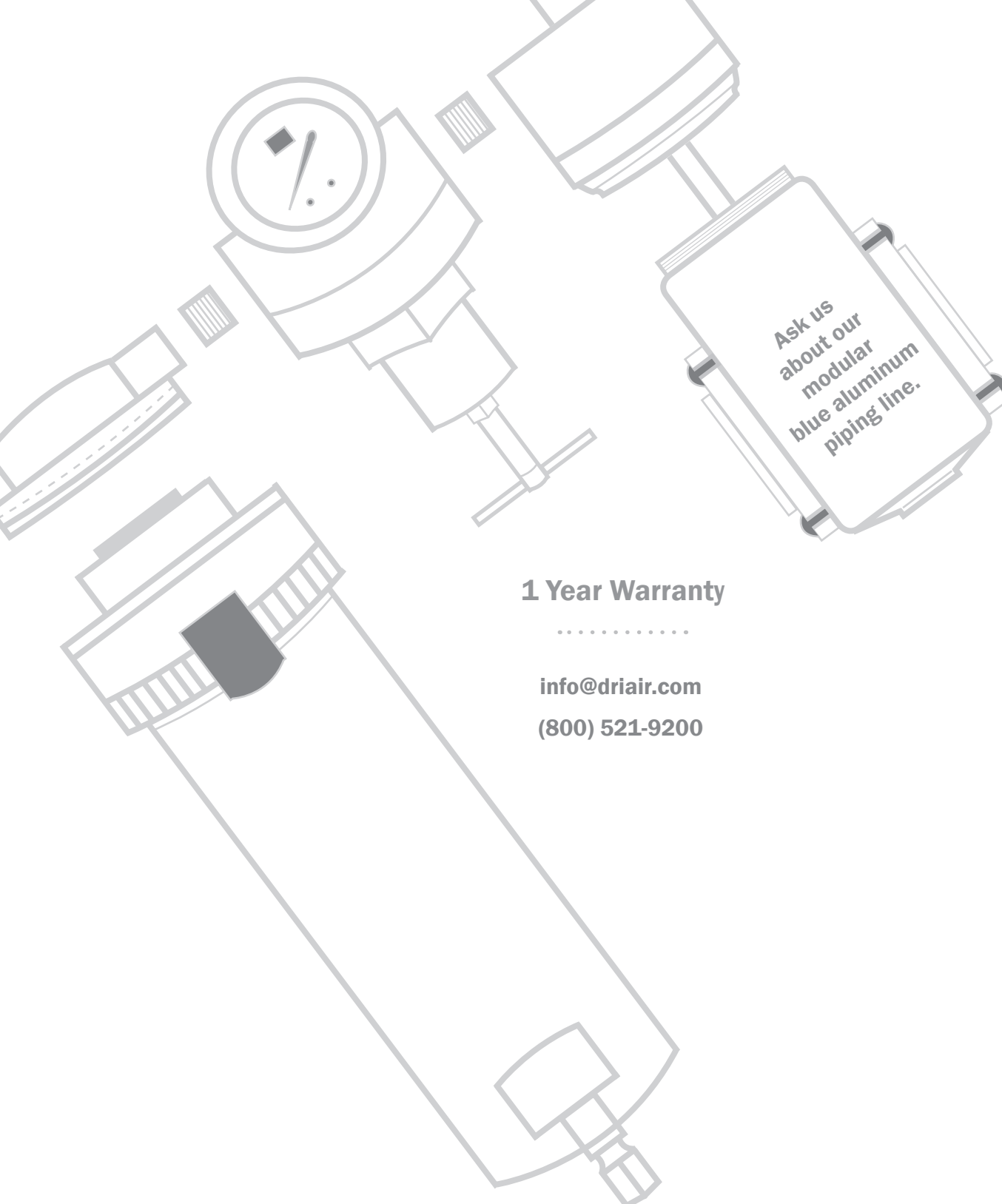

Ask us  
about our  
modular  
blue aluminum  
piping line.

## 1 Year Warranty

.....

[info@driair.com](mailto:info@driair.com)

(800) 521-9200

For applications  
outside of the  
industrial range,  
check out our  
*Automotive Product Line*  
on our website or call  
for more information.



**RTI** takes pride  
in giving our customers  
an **excellent**  
**customer service experience.**

From the employees  
in the corporate office  
to our regional sales managers,  
we strive to meet  
all of our customer's needs.

**We are not limited**  
to "standard" products.  
If you do not see  
what your customer needs, **ask us.**  
We can custom engineer  
a product or system that will exceed  
your needs and expectations.

**Support**  
for our product lines  
does not end after the ship date.  
Our Regional Sales Managers & Technical Support  
are available each business day.

**Because your business matters.**



